

AROMA[®]

Breakfast-To-Go[™] 3-in-1 Toaster Oven, Coffee Maker and Griddle



Instruction Manual

Model: ABT-203

Congratulations!

Your **AROMA** 3-in-1 Toaster Oven, Coffee Maker and Griddle will surely become one of the most versatile and practical appliances in your home. It will make your cooking fun and easy.

Please read the following instructions carefully before your first use.



Published By:

Aroma Housewares Co.
6469 Flanders Drive
San Diego, CA 92121
U.S.A.
1-800-276-6286
www.aromaco.com

© 2005 Aroma Housewares Company All rights reserved.

IMPORTANT SAFEGUARDS

Basic safety precautions should always be taken when using electrical appliances, including the following:

1. Read all instructions.
2. Do not touch hot surfaces. Use handle or knobs.
3. To protect against electrical shock, do not immerse cord, plugs or appliance in any liquid.
4. Close supervision is necessary when any appliance is used by or near children.
5. Unplug from outlet when not in use and before cleaning. Allow to cool before putting on or taking off parts, and before cleaning the appliance.
6. Do not operate any appliance with a damaged cord or plug or after the appliance malfunctions, or has been damaged in any matter. Return appliance to the nearest authorized service facility for examination, repair or adjustment.
7. The use of accessory attachments not recommended by the appliance manufacturer may result in fire, electric shock or injury to persons.
8. Do not use outdoors.
9. Do not let cord hang over edge of table or counter, or touch hot surfaces.
10. Do not place on or near a hot gas or electric burner, or in a heated oven.
11. Extreme caution must be used when moving an appliance containing hot oil or other hot liquids.
12. Always attach plug to appliance first, then plug cord into the wall outlet. To disconnect, turn any control to "off," then remove plug from wall outlet.
13. Do not use appliance for other than its intended use.
14. Be sure to operate the appliance on a dry, horizontal surface.
15. Oversized foods or metal utensils must not be inserted in the toaster oven as they may create a risk of fire or electric shock.
16. A fire may occur if the toaster oven is covered with or touching flammable material, including curtains, draperies, walls, and the like, when in operation. Do not store any items on top of the appliance when in operation.
17. Do not clean with metal scouring pads, as pieces of the pad can break off and create a risk of electric shock.
18. Extreme caution should be exercised when using containers constructed of other than metal or glass.

SAVE THESE INSTRUCTIONS

IMPORTANT SAFEGUARDS

19. Do not store any materials, other than manufacturers recommended accessories, in the oven when not in use.
20. Do not place any of the following materials in the oven: paper, cardboard, plastic, and the like.
21. Do not cover the crumb tray or the outside of the oven with metal foil. This will cause overheating of the oven.
22. Do not touch the hot plate while the appliance is in operation or immediately after being switched **off** as the hot plate will be hot.
23. To turn the toaster oven **off**, turn the timer dial to the "**off**" position.
24. Do not use the coffee carafe if it has been cracked or if its handle has become loose.
25. Do not clean the carafe with abrasive cleaners, pads, or other abrasive material.
26. To reduce the risk of fire or electric shock, do not attempt to disassemble the appliance. No user serviceable parts inside. Repair should only be done by authorized service personnel.
27. To reduce the risk of fire or electric shock, do not operate the unit unless the removable griddle is in place. Do not place any foods directly on the heating elements especially through the opening at the top of the unit.
28. Keep lid on carafe while serving coffee and brewing.
29. Appliances with glass containers:
 - A. The container is designed for use with this appliance. It must never be used on a range top. (Unless specific instructions for use on a range top are provided and include the precautions to be observed.)
 - B. Do not set a hot container on a set or cold surface.
 - C. Do not use a cracked container or a container having a loose or weakened handle.
 - D. Do not clean container with cleansers, steel wool pads, or other abrasive material.

SAVE THESE INSTRUCTIONS

SHORT CORD INSTRUCTIONS

1. A short power-supply cord is provided to reduce risk resulting from becoming entangled in or tripping over a longer cord.
2. Longer extension cords are available and may be used if care is exercised in their use.
3. If a longer extension cord is used:
 - a. The marked electrical rating of the extension cord should be at least as great as the electrical rating of the appliance.
 - b. The longer cord should be arranged so that it will not drape over the counter top or tabletop where it can be pulled by children or tripped over unintentionally.

POLARIZED PLUG

This appliance has a **polarized plug** (one blade is wider than the other); follow the instructions below:

To reduce the risk of electric shock, this plug is intended to fit into a polarized outlet only one way. If the plug does not fit fully into the outlet, reverse the plug. If it still does not fit, contact a qualified electrician. Do not attempt to modify the plug in any way.

DO NOT DRAPE CORD !



This appliance is for household use only.

PARTS IDENTIFICATION

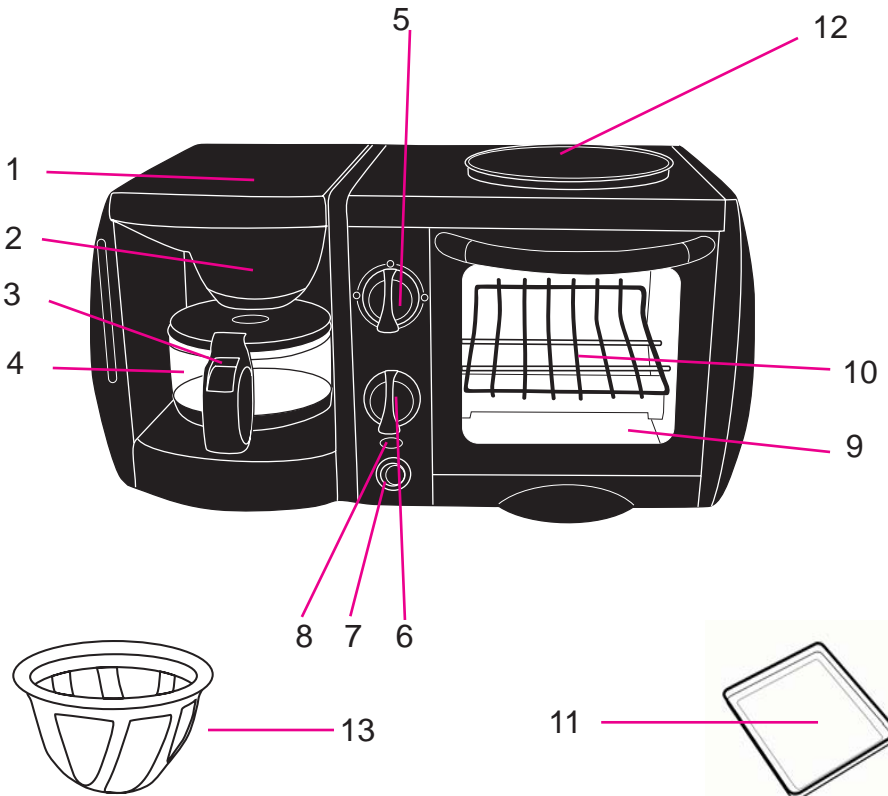

1. Water tank lid
2. Coffee filter cone
3. Coffee maker handle
4. Coffee carafe
5. Heating element (from Top and/or Bottom)
6. Timer
7. Coffee maker ON/OFF switch
8. Oven ON light
9. Oven glass door with handle
10. Chrome bake rack
11. Baking tray
12. Griddle plate
13. Coffee Filter

HOW TO USE

Before First Use:

1. Read all instructions and important safeguards.
 2. Remove all packaging materials and make sure items are received in good condition.
 3. Tear up all plastic bags as they can pose a risk to children.
 4. Wash accessories in warm soapy water. Rinse and dry thoroughly.
 5. Wipe body clean with a damp cloth.
- **Do not use abrasive cleaners or scouring pads.**
 - **Do not immerse the appliance cord or plug in water at any time.**

Toaster Oven:

Due to the manufacturing process, smoke and odor may be emitted during the first few uses. It is normal and causes no harm. We recommend pre-heating the toaster oven to eliminate the smoke and odor.

1. Ensure timer is set to the "OFF" position and plug into a 120V AC outlet.
2. Set the timer and pre-heat the oven for 15 minutes at the maximum temperature or until smoke and odor no longer exist.
3. Turn the timer to the "OFF" position and remove the plug from wall outlet.

Timer:

1. Always use timer control to turn ON the oven and griddle. To turn the oven on, turn the timer dial clockwise to select the time (maximum 15 minutes).
2. At the end of the set time the timer will ring loudly and the oven will switch OFF automatically.
3. The cooking process may be manually stopped by turning the timer dial counter clockwise to the "OFF" position.

Heating Function Selector

OFF	Appliance switched off
TOP	Upper element only switched on
BOTTOM	Lower element only switched on
TOP and BOTTOM	Both elements switched on

Note:

- In general, it is advisable to begin cooking with the selector in the TOP & BOTTOM position, and then turn it to the upper or lower position after a few minutes depending on the size and shape of the food.

HOW TO USE OVEN

1. Preheat the oven for 2 minutes prior to use, especially when using the baking tray. When toasting, place the food directly on the grill, without the baking tray. Keep the door closed while the oven is in use.
2. The oven may be used to defrost and heat up frozen food; the time will depend on the size and temperature of the food.
3. To ensure uniform defrosting, divide the food into small pieces and wrap them in aluminum foil.

CAUTION:

- Never operate oven with door completely open.
- Always use heatproof containers. Make sure the container fits properly prior to use.
- All cooking containers must be placed on the bake rack. Never set the baking tray directly on the lower heating elements.
- Remove all paper and plastic from any TV dinner dish before placing it in the toaster oven. Always read the cooking instructions on the package of TV dinner to make sure that it is toaster oven safe.
- Always use oven mitts or hot pads to remove food and trays from oven.
- Always make sure to shut-off and unplug the oven when not in use. To shut-off the unit during operation, turn the timer to "OFF".

HOW TO USE COFFEE MAKER

1. Fill the carafe with cold water. Open the coffee maker lid and pour water into water tank.
2. Swing the drip nozzle to the side, remove the reusable filter, and fill filter with coffee. Replace filter and swing the drip nozzle back into place. (See Diagram 1)
3. Return the carafe to its place under the filter cone and close the coffee maker lid.
4. Turn the coffee maker switch on. Coffee can be kept warm while the carafe rests on the hot plate. Turn off if empty.

Diagram 1

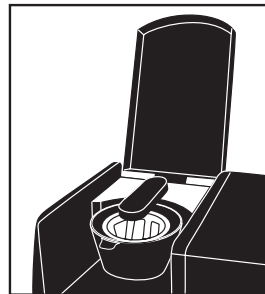
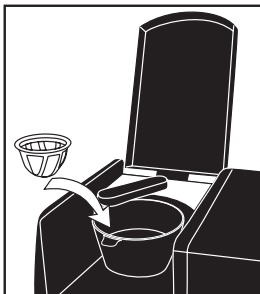

Helpful Tip

The toaster oven has been designed to utilize everyday recipes, but temperatures and times may vary. We recommend that you monitor the cooking process by checking your meals frequently during operation to ensure ideal cooking results.

HOW TO CLEAN

Always unplug unit and allow to cool completely before cleaning.

1. Use a damp cloth to clean the outside, and a dry one to clean the inside. Never use abrasive detergents or other products that may cause scratching.
2. The baking tray is dishwasher safe. The crumb collector tray may be removed and cleaned with a damp cloth. Dry completely before returning to the toaster oven. Clean the crumb tray on a regular basis.
3. Take special care not to touch the heating elements when cleaning the inside of the oven.

CAUTION:

- Make certain crumb tray is cleaned on a regular basis. Accumulated crumbs can cause a fire.

LIMITED WARRANTY

Aroma Housewares Company warrants this product free from defects in material and workmanship for one year from provable date of purchase in continental United States.

Within this warranty period, Aroma Housewares Company will repair or replace, at its option, defective parts at no charge, provided the product is returned, freight prepaid with proof of purchase and U.S. \$6.00 for shipping and handling charges payable to Aroma Housewares Company. Before returning an item, please call the toll free number below for return authorization number. Allow 2-4 weeks for return shipping.

This warranty does not cover improper installation, misuse, abuse or neglect on the part of the owner. Warranty is also invalid in any case that the product is taken apart or serviced by an unauthorized service station.

This warranty gives you specific legal rights and which may vary from state to state and does not cover areas outside the United States.

AROMA HOUSEWARES COMPANY
6469 Flanders Drive
San Diego, California 92121
1-800-276-6286
M-F, 8:30 AM - 5:00 PM, Pacific Time
Website: www.aromaco.com