

# AROMA<sup>®</sup>

## *Stainless Steel Deep Fryer*



## **Instruction Manual**

*Model ADF-190A*

Congratulations!

Your **AROMA** Stainless Steel Deep Fryer will give your kitchen a professional look, while providing you with delicious meals night after night.

Please read the following instructions carefully before your first use.



Published By:

Aroma Housewares Co.  
6469 Flanders Drive  
San Diego, CA 92121  
U.S.A.  
1-800-276-6286  
[www.aromaco.com](http://www.aromaco.com)

© 2005 Aroma Housewares Company All rights reserved.

# IMPORTANT SAFEGUARDS

*Basic safety precautions should always be followed when using electrical appliances, including the following:*

1. Read all Instructions before first use.
2. Do not touch hot surfaces. Use handles or knobs.
3. To protect against electrical shock, do not immerse cord, plugs or appliance in water or other liquid.
4. This appliance is not intended to be used by children. Close supervision is necessary when the appliance is used near children.
5. Do not leave appliance unattended while in use.
6. Unplug from outlet when not in use and before cleaning. Allow to cool before putting on or taking off parts, and before cleaning the appliance.
7. Do not operate any appliance with a damaged cord or plug or after the appliance malfunctions or has been damaged in any manner. Return appliance to the nearest authorized service facility for examination, repair or adjustment.
8. The use of accessory attachments not recommended by the appliance manufacturer may cause injuries.
9. Do not use outdoors.
10. Do not let cord hang over the edge of counter or table, or touch hot surfaces.
11. Do not place on or near a hot gas or electric burner, or in a heated oven.
12. Extreme caution must be used when using or moving an appliance containing hot oil or other hot liquids.
13. Always attach plug to appliance first, then plug cord into the wall outlet. To disconnect, turn any control to "OFF", then remove plug from wall outlet.
14. Do not use appliance for other than intended use.
15. Use only metal cooking utensils in the fryer as rubber or plastic utensils will become damaged from the hot oil. Do not leave metal utensils in the fryer as they will become very hot and may cause injuries.
16. To assure safe operation and avoid possible fire, oversized foods must not be inserted into the appliance.
17. Extreme caution must be used when moving fryer containing hot oil. Be sure handles are properly assembled to basket and locked in place. See detailed assembly instructions [visual reference.]

**SAVE THESE INSTRUCTIONS**  
**Product for Household Use Only.**

# SHORT CORD INSTRUCTIONS

1. A short power-supply cord is provided to reduce risk resulting from becoming entangled in or tripping over a longer cord.

## POLARIZED PLUG

This appliance has a **polarized plug** (one blade is wider than the other); follow the instructions below:

To reduce the risk of electric shock, this plug is intended to fit into a polarized outlet only one way. If plug does not fit fully into the outlet, reverse the plug. If it still does not fit, contact a qualified electrician. Do not attempt to modify the plug in any way.

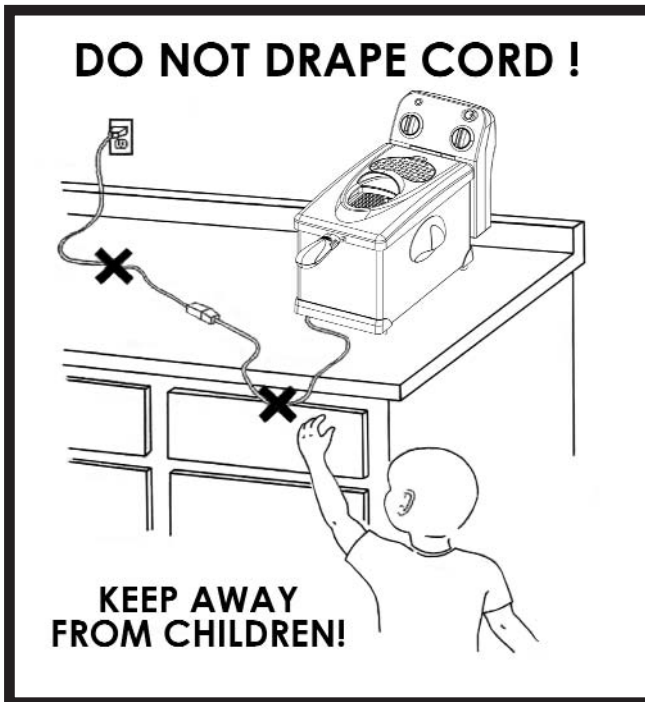

**This appliance is for household use only.**

# PARTS IDENTIFICATION

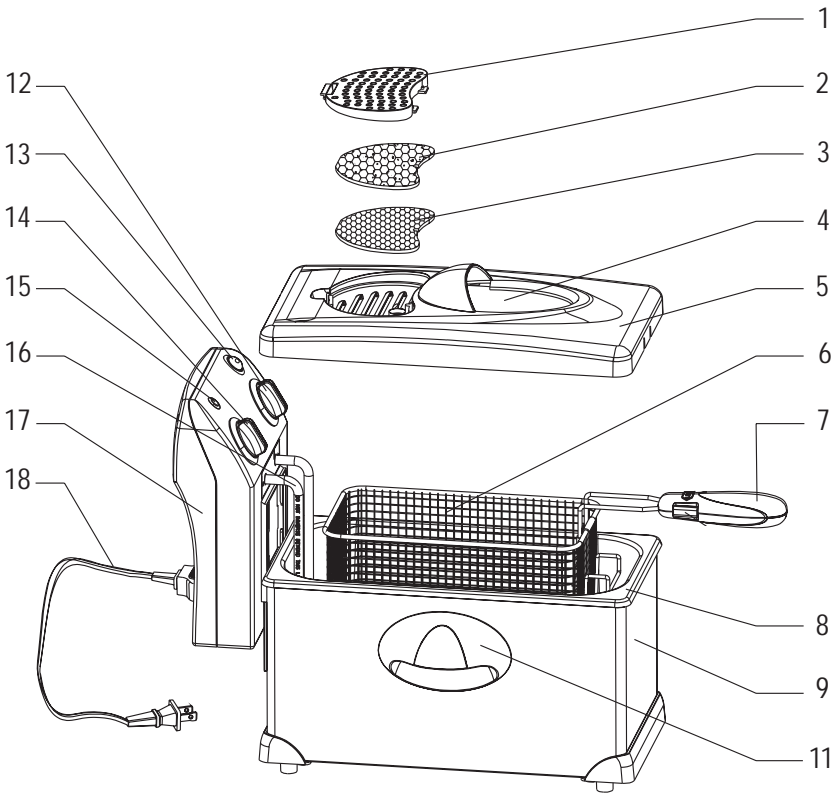

- |                        |                                    |
|------------------------|------------------------------------|
| 1. Filter Cover        | 9. Stainless Steel Body            |
| 2. Charcoal Filter     | 10. Cool-Touch Body Handle         |
| 3. Anti-Vapor Filter   | 11. Thermostat Knob                |
| 4. Viewing Window      | 12. Power Switch                   |
| 5. Lid                 | 13. Timer Knob                     |
| 6. Frying Basket       | 14. Pre-heat/Ready Indicator Light |
| 7. Cool-Touch Handle   | 15. Heating Element                |
| 8. Removable Inner Pot | 16. Electrical Unit                |
|                        | 17. Power Cord                     |

## CALL FOR FILTERS

- Replacement filters are available through AROMA Customer Service at 1-800-276-6286.
- The life of the filter varies according to the type of food fried and the frequency of use.
- Aroma Housewares Company recommends the filter be replaced after 30 times of operation.

# VISUAL REFERENCE

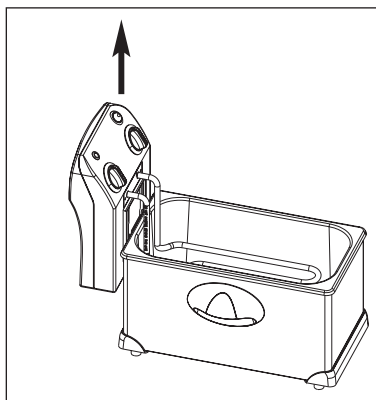

Fig. 1

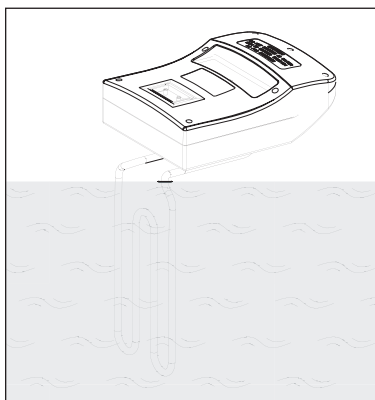

Fig. 2

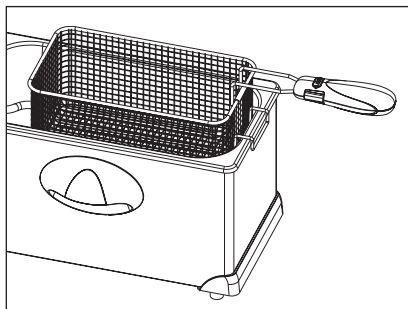

Fig. 3

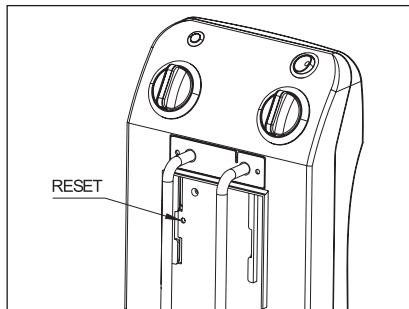

Fig. 4

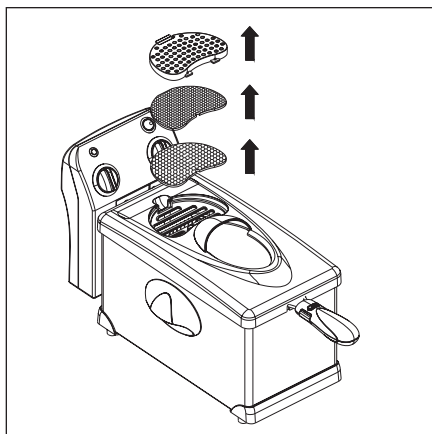

Fig. 5

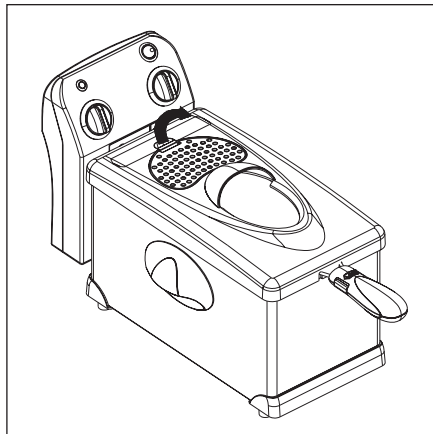

Fig. 6

# HOW TO USE

## Before First Use:

1. Read all instructions and important safeguards.
  2. Remove all packaging materials and make sure items are received in good condition.
  3. Tear up and discard all plastic bags as they can pose a risk to children.
  4. Wash accessories and inner pot in warm soapy water. Rinse and dry thoroughly. As pictured in Fig. 2 on page 4, the heating element can be immersed in water, but never immerse the Electrical Unit. Dry the heating element thoroughly before use.
  5. Wipe the body clean with a damp cloth.
  6. Place the deep fryer on a level, stable surface.
- **Do not use abrasive cleaners or scouring pads.**
  - **Do not immerse the appliance in water at any time.**

## Oil Selection:

1. We recommend the following oils for healthier deep-frying: corn, canola or blended vegetable oil. These oils are cholesterol-free and low in saturated fat.
2. We do not recommend using peanut oil, soy oil, sun flower oil, or lard that may drip and deteriorate quickly when heated. Heavy flavored oil such as olive oil should also be avoided.
3. We do not recommend mixing old and new oil together as this spoils new oil quicker.
4. The number of times that the frying oil can be reused would depend on the food that is fried in it. For example, when food such as coated fish battered with bread or cracker crumbs is fried frequently, the oil will need to be replaced more often.

## Preheat Oil:

1. Turn the temperature control to the lowest temperature and make sure that the fryer is unplugged.
2. Wipe dry the Non-Stick Frying Pot and fill it with oil no higher than the MAX Level and no lower than MIN level.
3. Be sure oil level is no higher than the MAX LINE marked on the pot. Oil level must always be between the minimum and maximum line marks.
4. Plug the fryer into a wall-outlet and turn on the power using the power switch. The power switch will illuminate and the indicator light will turn red.
5. Close the lid tightly.
6. Set the temperature control to the desired degree and the fryer will start heating oil.
7. When the oil reaches the desired temperature, the indicator light will turn green.

# HOW TO USE (CONT)

## To fry:

1. For foods that are not coated with batter, place directly in the frying basket. Be sure not to fill frying basket more than 2/3 full. Over filling will cause food to cook improperly and could cause the oil to bubble over.
2. Lower basket carefully into oil.
3. For foods coated with batter, first lower frying basket into oil and gently place foods directly into oil. This will prevent the food coated with batter from sticking to the bottom of the fry basket.

**Note:** Always shake frozen foods to remove ice particles prior to frying. Pat dry fresh-cut French fries and other damp foods before frying as moist food may cause excess foaming and spattering of oil.

4. Replace the lid securely.
5. See the Deep Frying Time Table on page 6 for recommended cooking times.
6. When frying is complete, remove the lid and lift the fry basket out of the oil by simply lifting the cool-touch frying basket handle. Hook the basket onto the edge of the pot, as seen in Fig. 3 on page 4. Now the frying basket is raised and the excess oil will drain.
7. Carefully remove the fried food from the frying basket. Be cautious of the hot oil that might spatter from the frying pot.
8. To turn off the deep fryer, you must unplug it from the wall outlet.
9. Allow the oil to cool completely before moving or cleaning the appliance. (3-4 hours)

## Resetting the Deep Fryer

In the event that the deep fryer is turned on without containing oil, the heating element will heat up very rapidly. The deep fryer's electrical unit will automatically shut down the heating element if this occurs. After the unit has completely cooled, remove the electrical unit and heating element and press the Reset button pictured in Fig. 4 on page 4. If this is not done, the unit will not function.

# HOW TO CLEAN

Always unplug unit and allow to cool completely before cleaning.

## Changing Oil:

The oil does not need to be changed after each use. It is recommended that the oil be changed after using approximately 5 to 8 times or sooner when frying heavily flavored or battered foods. The oil should be completely changed when it has the following symptoms: unpleasant odor, smoke when frying or when the color becomes darker.

## Storing Oil:

The oil may be stored in the fryer at room temperature (only if the fryer is used on a regular basis) or you may store the oil in a separate container in the refrigerator.

**Note: Do not attempt to place oil into a separate container until the oil has completely cooled down to room temperature.**

## To Clean:

1. Wash the basket and lid with a sponge or dishcloth in warm soapy water.
  3. To clean the inner pot, pour warm water and dish soap into the pot and use a sponge or dishcloth to remove grease. Empty the pot and rinse with warm water.
  4. Dry the pot completely before next use.
  5. Clean the body of the fryer with a damp cloth and then dry.
  6. To clean the heating element, rinse with water or immerse in soapy water as pictured in Fig. 2 on page 4. Wipe with damp cloth and dry thoroughly before next use.
- Do not use harsh abrasive cleaners or products that are not considered safe to use on nonstick coatings.
  - Do not attempt to cool the unit by pouring cold water into the pot.
  - Do not immerse the electrical unit in water or any other liquid.

## Changing Filter:

It is recommended that the carbon filter (black) be changed every 6 months and the vapor filter (white) once a year. These recommendations are approximate and the filters should be changed depending on amount of usage. To change, unclip filter cover, remove filters and replace with new ones as pictured in Fig. 5 and 6 on page 4. See page 3 for filter ordering information.

# RECIPES

## Deep Fried Onion Blossom

Canola oil or blended vegetable oil for frying  
1 large onion  
2 eggs  
½ cup beer  
½ cup milk  
2 cups all-purpose flour  
½ teaspoon baking soda  
½ teaspoon black pepper

Preheat oil to 375° F. Peel onion and cut the bottom off. Cut the onion into ¾-inch wedges without cutting all the way through the base.

Soak onion in ice cold water until wedges open. Approximately 7-12 minutes. Drain onion and pat dry. Mix together eggs, beer and milk. In a separate bowl mix flour, baking soda and black pepper.

Dust the onion with the flour mixture. Dip the onion in the batter. Re-dust with the flour mixture. Shake off the excess. Make sure that the onion is completely coated.

Carefully lower the blossom into hot oil being very careful to avoid splattering. Cook for 2 minutes. Turn onion and cook for an additional 2 minutes or until golden brown. Lift the cooked blossom from the oil. Sprinkle with salt and pepper to taste.

## Vegetarian Egg Rolls

Corn oil for frying  
6 egg roll wrappers  
2 green onions, minced  
¼ lb. minced white button mushrooms  
2 oz. grated carrot  
1 teaspoon minced ginger and garlic  
2 soaked and minced dried black mushrooms  
1 teaspoon sesame oil  
1 teaspoon salt  
¼ cup bean sprouts  
1 teaspoon chopped roasted peanuts

# RECIPES CONTINUED

Preheat oil to 375 °F. Heat 2 teaspoons of corn oil in a fry pan over medium heat. Add garlic, ginger and green onions. Cook for 2 minutes. Add button mushrooms and black mushrooms. Cook for 3 minutes. Add salt to taste. Stir in peanuts, carrots, bean sprouts and sesame oil, turn off heat.

To prepare egg roll wrappers put 2 ½ teaspoons filling in each one. Roll up, tucking in edges over filling. Seal the edge with a drop of thick flour paste.

Deep fry 3 rolls at a time for approximately 4-6 minutes or until the egg rolls are golden brown all sides. Carefully lift the cooked egg rolls from the fryer. Let drain in the basket then pat dry with paper towels.

## Fried Chicken Tenders

4 boneless, skinless chicken breasts

1 cup bread crumbs

1 teaspoon lemon juice

1 tablespoon dried basil leaves

1 cup flour

½ teaspoon of salt and pepper

½ cup milk

1 cup vegetable oil

Preheat oil to 350°F. Cut the chicken in even strips, about 1 inch X 2 inch. Marinade chicken with salt, pepper, basil leaves and lemon juice for about 30 minutes. Coat chicken breasts evenly with flour and bread crumbs.

Deep fry chicken strips at 350°F for 8-10 minutes. Let drain in the basket and serve with honey mustard or sweet sour sauce

# RECIPES CONTINUED

## Fried Jumbo Shrimp

Canola oil for frying  
14 large shrimp in the shell  
1 teaspoon salt  
½ teaspoon white pepper  
3 teaspoons corn starch  
1 teaspoon Japanese rice wine

Preheat oil to 350°F. De-vein shrimp by cutting a slit on the shell along the back of shrimp. Season shrimp with rice wine and salt, let it sit about 20 minutes.

Evenly dust each shrimp with cornstarch. Add shrimps to the frying basket, lower basket into oil. Fry 4 - 5 minutes or until shrimp has reached desired doneness, color and crispness.

Let drain in the basket then pat dry with paper towels.  
Garnish with lettuce leaves and lemon slices.

## Fontina Cheese Fritos (Fritters)

Corn oil for frying  
¾ lb. chilled fontina cheese  
2 egg yolks and keep the egg white  
½ cup minced fresh basil  
1 ½ cups unbleached flour  
2/3 cup ice water  
1 teaspoon baking powder  
salt to taste  
3 teaspoon olive oil

Preheat oil to 350°F. Cut cheese into 1-inch cubes. Mix wine, egg yolks and garlic in a bowl. Add baking powder, flour, ½ teaspoon salt, olive oil and water. Mix until smooth. Let rest at room temperature for 2 hours.

Beat egg whites with a pinch of salt until barely stiff. Fold into batter along with minced basil.

Dip cheese chunks into batter. Drip off excess batter. Lower cheese chunks into oil until golden. Approximately 1-1 ½ minutes. Drain and remove from basket and serve immediately.

# RECIPES CONTINUED

## Aroma's Favorite Fried Banana

Canola oil for frying  
1 cup all purpose flour  
½ tsp. salt  
1 tbsp. sugar  
1 egg, lightly beaten  
1 cup milk  
¼ cup powder sugar  
3 strings of bananas, cut into 1 inch length

Preheat oil to 370°F. Mix flour, sugar and salt in a large bowl. Combine and mix well egg, milk and 2 tsp. of heated vegetable oil in another bowl. Combine egg mixture with flour paste.

Stir with a fork or whisk until the batter is smooth. Dip each 1-inch long banana into batter and drip off the excess batter. Place frying basket in preheated oil in deep fryer.

Slowly place battered banana with a draining spoon into frying basket, one at a time. Fry all bananas until golden brown, about 3 to 4 minutes. Drain excess oil in clean paper towel. Sprinkle fried bananas with powder sugar and serve immediately.

# COOKING GUIDES

Food Selection	Quantity	Temp.	Approximate Time
French Fries	10 oz.	375°F	5-7 min.
French Fries (Frozen)	10 oz.	350°F	6-8 min.
Chicken Strips (Fresh)	12 oz.	375°F	9-11 min.
Chicken Nuggets (Frozen)	10 oz.	375°F	3-4 min.
Chicken Drumsticks	1/2 Basket	300°F	7-8 min.
Fish (Fresh)	8 oz.	375°F	4-6 min.
Fish (Frozen)	8 oz.	350°F	5-7 min.
Shrimp	8 oz.	375°F	4-5 min.
Onion Rings (Fresh)	6 oz.	350°F	3-4 min.
Fresh Vegetables	10 oz.	350°F	2-3 min.
Doughnuts	2-3.	325°F	1 min. each

*Note: Cooking times and temperatures given here are only a guide. They may vary due to differences in meat and temperature of refrigerated food. Adjust your cooking time and temperature to your preference.*

## Helpful Hints for Deep Frying:

- Prepare food to be fried in equal size and thickness so that they will fry more evenly and at the same speed.
- Do not fill the frying basket over 2/3 full. If too much food is fried at the same time, food may not be fried crispy and evenly.
- Before deep frying, always remove excess moisture or ice crystals from food by rubbing with paper towel. Moist food may cause excess foaming and spattering of oil.
- **Do not drop the frying basket quickly into the hot oil to avoid overflow or the splashing hot oil.**
- **During frying, hot steam will escape through the edge of the lid. This is normal. Avoid this area when the fryer is in use.**
- **The fryer may give off a slight odor and smoky haze during the first use. This is normal and is due to the newness of the product.**
- **When opening the lid, be extremely cautious to the splashing hot oil.**

# LIMITED WARRANTY

Aroma Housewares Company warrants this product free from defects in material and workmanship for one year from provable date of purchase in the continental United States.

Within this warranty period, Aroma Housewares Company will repair or replace, at its option, defective parts at no charge, provided the product is returned, freight prepaid with proof of purchase and U.S. \$8.00 for shipping and handling charges payable to Aroma Housewares Company. Before returning an item, please call the toll free number below for return authorization number. Allow 2-4 weeks for return shipping.

This warranty does not cover improper installation, misuse, abuse or neglect on the part of the owner. Warranty is also invalid in any case that the product is taken apart or serviced by an unauthorized service station.

This warranty gives you specific legal rights which may vary from state to state and does not cover areas outside the United States.

AROMA HOUSEWARES COMPANY  
6469 Flanders Drive  
San Diego, California 92121  
1-800-276-6286  
M-F, 8:30 AM - 5:00 PM, Pacific Time  
Website: [www.aromaco.com](http://www.aromaco.com)