

AROMA[®]

Electric Skillet



Instruction Manual &
Cooking Guide

Models: AFP-1210G

Congratulations on your purchase of the **AROMA** Electric Skillet. It will surely become one of the most practical appliances in your kitchen.

Please read all instructions before first use.

Published By:

Aroma Housewares Co.
6469 Flanders Drive
San Diego, CA 92121
U.S.A.
1-800-276-6286
www.aromaco.com

© 2004 Aroma Housewares Company All rights reserved.

IMPORTANT SAFEGUARDS

Basic safety precautions should always be followed when using electrical appliances, including the following:

1. Read all instructions carefully before first use.
2. Do not touch hot surfaces. Use handles or knobs.
3. Use only on a level, dry, and heat-resistant surface.
4. To protect against electrical shock, do not immerse cord, plug or the appliance itself in water or any other liquid.
5. Close supervision is necessary when the appliance is used near children. This appliance is not intended to be used by children.
6. Unplug from outlet when not in use and before cleaning. Allow unit to cool before putting on or taking off parts, and before cleaning the appliance.
7. Do not operate any appliance with a damaged cord or plug or after the appliance malfunctions or has been damaged in any manner. Return appliance to the nearest authorized service facility for examination, repair or adjustment.
8. Do not use attachments or accessories other than those supplied or recommended by the manufacturer. Incompatible parts create a hazard.
9. Do not use outdoors.
10. Do not let cord hang over edge of table or counter, or touch hot surfaces.
11. Do not place on or near a hot burner or in a heated oven.
12. Do not use the appliance for other than intended use.
13. Extreme caution must be used when using or moving an appliance containing hot oils or other hot substances.
14. Do not touch the steam vent on the top of the skillet or the lid during or after use as it is extremely hot and may cause scalding.
15. Do not clean with metal scouring pads as small particles may break off the pad and contact electrical parts, creating a risk of electric shock. Metal scouring pads also may damage the finish.
16. Avoid sudden temperature changes when using the skillet.
17. Use only with 120V AC power outlet.
18. Use only the Aroma® Temperature Control Probe when operating the appliance.
19. Ensure that handles are assembled and securely fastened.

SAVE THESE INSTRUCTIONS

SHORT CORD INSTRUCTIONS

1. A short power-supply cord is provided to reduce risk resulting from becoming entangled in or tripping over a longer cord.
2. Longer extension cords are available and may be used if care is exercised in their use.
3. If a longer extension cord is used:
 - a. The marked electrical rating of the extension cord should be at least as great as the electrical rating of the appliance.
 - b. The longer cord should be arranged so that it will not drape over the counter top or tabletop where it can be pulled by children or tripped over unintentionally.

POLARIZED PLUG

This appliance has a **polarized plug** (one blade is wider than the other); follow the instructions below:

To reduce the risk of electric shock, this plug is intended to fit into a polarized outlet only one way. If the plug does not fit fully into the outlet, reverse the plug. If it still does not fit, contact a qualified electrician. Do not attempt to modify the plug in any way.

This appliance is for household use only.

PARTS IDENTIFICATION

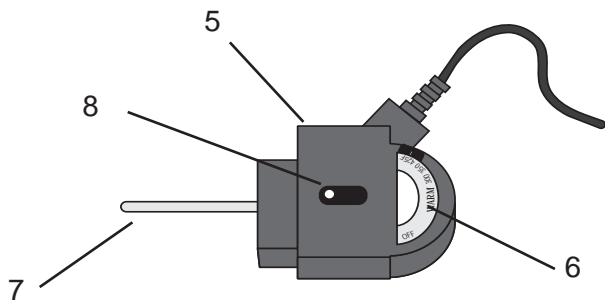
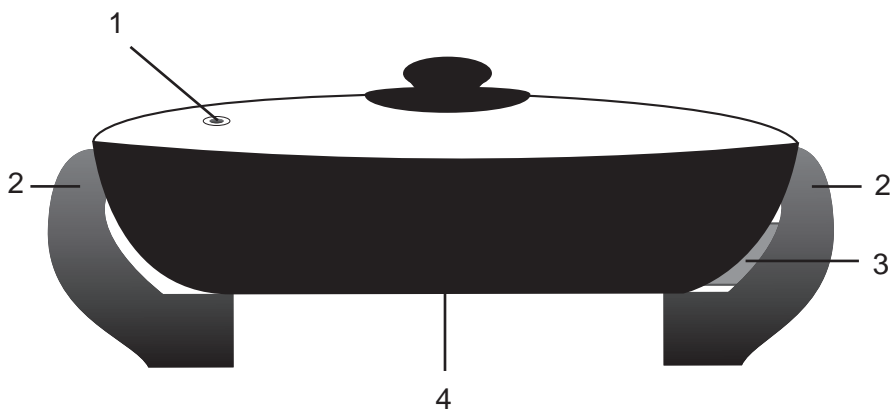

1. Lid with steam vent
2. Handles
3. Control probe base
4. Reflector plate
5. Control probe
6. Temperature control dial
7. Control probe connector
8. Indicator light

HOW TO USE

Before First Use:

1. Read all instructions and important safeguards.
 2. Remove all packaging materials and make sure items are received in good condition.
 3. Tear up all plastic bags as they can pose a risk to children.
 4. Wash accessories in warm soapy water. Rinse and dry thoroughly.
 5. Wash the skillet and lid using the cleaning instructions on page 5.
- Do not use abrasive cleaners or scouring pads.
 - Do not immerse the temperature-control probe in water or any other liquid.
 - To prevent injury or damage of product, make sure all handles are securely attached before use.

Condition:

The interior surface must be conditioned to ensure nonstick cooking.

1. Apply cooking oil, with a cloth or paper towel, to the interior nonstick surface.
2. Wipe off excess oil. The skillet is now ready for use.

How to Use:

1. Attach the temperature-control probe firmly into its socket, found at the side of the unit. Be sure the selector is set to OFF. Plug the cord into a 120-volt wall outlet.
2. Slide the selector to the desired temperature. The indicator light on the temperature-controller will illuminate. When the skillet has reached the desired cooking temperature, the light will go out. You may now add food.
3. When you have finished cooking, set the temperature-selector to "Warm" for serving.
4. When finished using appliance, slide the selector to the OFF position, unplug from the wall outlet and remove temperature-controller from the skillet.

NOTE:

- The "Reflector Plate" on the under side of skillet reduces the heat that is given off from the bottom of pan so that skillet may be taken to the tabletop as a serving dish.
- Wood and plastic coated spatulas (suitable for hot surfaces) are recommended to preserve the nonstick coating. Metal tools may damage the nonstick surface.

HOW TO CLEAN

Always unplug unit and allow to cool completely before cleaning.

1. Unplug and remove the temperature-control probe.
 2. Wash the skillet and lid with a dishcloth in warm soapy water, or use in a dishwasher. The skillet and lid are fully submersible.
 3. Rinse and dry thoroughly.
- Do not use harsh abrasive cleaners or products that are not considered safe to use on nonstick coatings.
 - Do not immerse the temperature-control probe, cord, or plug in water or any other liquid.

CAUTION:

- Do not attempt to cool the unit by pouring cold water into it. This sudden temperature change may cause the product to warp.
- Ensure that the probe connector, located on the side of the skillet, is thoroughly dried after washing and before using.

COOKING GUIDES

Food Selection	Temperature Settings	Approximate Time
Pancakes	375°F	1-3 min
French Toast	350°F	4-5 min
Bacon	375°F	4-7 min
Hash Browns	400°F	8-10 min
Eggs	300°F	2-5 min
Hamburgers	375°F	5-12 min
Fish	350°F	6-9 min
Pork Chops	375°F	10-15 min
Ham Steak Slices	350°F	10-15 min
Sausage	350°F	10-12 min
Potatoes	325°F	10-12 min
Chicken	375°F	10-15 min

Cooking times and temperatures given here are only a guide. They may vary due to differences in meat and temperature of refrigerated food. Adjust your cooking time and temperature to your preference.

RECIPES

ITALIAN CHEESE CHICKEN BREAST STIR FRY

2 Medium Skinless Chicken Breasts
2 oz. Fresh Parsley, chopped
4 oz. Shredded Italian Cheese
2 oz. White Onion, finely chopped
2 tbsp Vegetable Oil
1 tsp Fresh Garlic, minced
½ tsp Salt
1 tsp Cornstarch
½ tsp Japanese Rice Wine
White Pepper to taste

Cut chicken breasts into 1-inch pieces. Marinate chicken with salt and cornstarch in a medium bowl. Refrigerate for 20 minutes.

Preheat the skillet to 375° F. Add vegetable oil, then add garlic and onion, and heat for 1 minute. Add marinated chicken and continue to stir-fry for about 5 to 6 minutes. When the chicken is half cooked and generates juices in the skillet, add parsley and shredded Italian cheese. Stir-fry to melt the cheese for about 2 minutes. Add rice wine and white pepper, adjust the amount of salt to taste. Cover with lid and simmer for 3 minutes. Serve hot with pasta or white rice. Makes 4 servings.

POTATO FRITTATA

16 oz. Lean Turkey Sausage
2 Green Onions, chopped
4 Russet Potatoes, thinly sliced
½ cup Sliced Mushrooms
½ Green Bell Pepper, chopped
8 Eggs

Cook sausage, continually stirring, at 375° F until browned. Drain and remove sausage from skillet, reserving 2 tablespoons of drippings. Combine green onions, potatoes, mushrooms and bell pepper into the skillet. Cook until potatoes are browned and tender. In a large bowl, combine sausage and potato mixture with beaten eggs. Pour the entire mixture back into the skillet, spreading evenly. Cover with lid and cook at 375° F for about 15-20 minutes.

RECIPES

BLUE CHEESE BURGERS

- 1 ½ lbs. Lean Ground Beef
- ¼ cup Onion, finely chopped
- 1 Garlic Clove, pressed
- ¼ tsp Salt
- ¼ tsp Pepper
- 2 oz. Bleu Cheese, crumbled
- 4 Hamburger Buns

Combine ground beef, onions, garlic, salt and pepper; mix well. Shape beef mixture into eight thin patties. Sprinkle crumbled bleu cheese atop four of the patties, covering with the remaining patties. Place burgers in skillet and cook at 375° F for 15 minutes, turning once. Serve patties on hamburger buns.

TURKEY WITH MUSHROOM SAUCE

- 4 Turkey Cutlets
- ½ cup All-Purpose Flour, divided
- 1 Garlic Clove, pressed
- ½ tsp Salt
- ½ tsp Pepper
- ¼ cup Butter or Margarine, divided
- 1 cup Sliced Mushrooms
- 1 can Chicken Broth (14.5 oz.)

Coat turkey in ¼ cup flour, seasoned with salt and pepper. Melt 1 tablespoon of butter in the skillet. Add turkey and cook at 375° F until lightly browned (about 3-5 minutes per side); drain. Transfer turkey to a serving platter, covering to retain heat. Heat remaining butter and add mushrooms and garlic. Saute for 5 minutes. Stir in remaining flour and cook until bubbly. Stir broth into skillet and stir continuously, until slightly thickened. Drizzle sauce over turkey and serve.

RECIPES

BARBECUE CHICKEN

- 4 Chicken Breasts
- ½ cup Butter or Margarine
- ¾ cup Lemon Juice
- 2 tsp Garlic Salt
- 2 tbsp Cumin
- 2 tbsp Cayenne Pepper
- 1 tsp Salt
- ½ tsp Pepper

Set skillet temperature to 300° F and melt butter. Add lemon juice, garlic salt, cumin and cayenne pepper. Pour ½ of this marinade into a large bowl. Pierce chicken in several places and sprinkle with salt and pepper. Place chicken in bowl with marinade, turning occasionally to coat. Set skillet temperature to 375° F. Place chicken in skillet, brushing with the reserved marinade. Grill, turning and basting with marinade occasionally, until thoroughly cooked (about 15 minutes).

BEEF STEW

- 4 cups Water
- 5 Beef Bouillon Cubes
- 1 tsp Worcestershire Sauce
- 2 cups Cooked Beef, cubed
- 6 Carrots, Peeled and cut into chunks
- 1 Medium Onion, chopped
- 2 tbsp Flour
- 1 Garlic Clove, Minced
- 1 Small Bay Leaf

Set temperature to 350° F. Bring water and bouillon cubes to a boil until bouillon dissolves completely. Add Worcestershire sauce and a dash of pepper. Stir beef, carrots and garlic into mixture and return to a boil, adjusting temperature if necessary. Place bay leaf on top, cover and reduce heat. Simmer for 30 minutes or until vegetables are tender. Pour about ½ of the liquid in a small bowl and blend with flour. Increase heat to boiling point. Stir flour mixture into stew and cook, stirring continually until juices are thickened. Remove bay leaf.

LIMITED WARRANTY

Aroma Housewares Company warrants this product free from defects in material and workmanship for one year from provable date of purchase in continental United States.

Within this warranty period, Aroma Housewares Company will repair or replace, at its option, defective parts at no charge, provided the product is returned, freight prepaid with proof of purchase and U.S. \$6.00 for shipping and handling charges payable to Aroma Housewares Company. Before returning an item, please call the toll free number below for return authorization number. Allow 2-4 weeks for return shipping.

This warranty does not cover improper installation, misuse, abuse or neglect on the part of the owner. Warranty is also invalid in any case that the product is taken apart or serviced by an unauthorized service station.

This warranty gives you specific legal rights which may vary from state to state and does not cover areas outside the United States.

AROMA HOUSEWARES COMPANY
6469 Flanders Drive
San Diego, California 92121
1-800-276-6286
M-F, 8:30 AM - 5:00 PM, Pacific Time
Website: www.aromaco.com