

AROMA[®]

Double Electric Range



Instruction Manual &
Recipes

Model: AHP-311

Congratulations on your purchase of the **AROMA** Double Electric Burner. This will surely become one of the most useful and versatile appliances in your modern kitchen.

Please read all instructions before your first use.



Published By:

Aroma Housewares Co.
6469 Flanders Drive
San Diego, CA 92121
U.S.A.
1-800-276-6286
www.aromaco.com

© 2005 Aroma Housewares Company. All rights reserved.

IMPORTANT SAFEGUARDS

Basic safety precautions should always be followed when using electrical appliances, including the following:

1. Important: Read all instructions carefully before first use.
2. Do not touch hot surfaces. Use handles or knobs.
3. To protect against electrical shock, do not immerse cord, plugs, or electrical burners in water or other liquid.
4. Close supervision is necessary when any appliance is used by or near children. This appliance is not intended to be used by children.
5. Unplug from outlet when not in use and before cleaning. Allow to cool completely before putting on or taking off parts.
6. Do not operate any appliance with a damaged cord or plug or after the appliance malfunctions or has been damaged in any manner. Return appliance to the nearest authorized service facility for examination, repair, or adjustment.
7. The use of accessory attachments not recommended by the appliance manufacturer may cause injuries.
8. Do not use outdoors.
9. Do not let cord hang over edge of table or counter, or touch hot surfaces.
10. Do not place on or near a hot gas or electric burner, or in a heated oven.
11. Extreme caution must be used when moving an appliance containing hot oil or other hot liquids. Do not attempt to move appliance with cookware on top.
12. To disconnect, turn controls to "OFF" position, then remove plug from wall outlet.
13. Do not use appliance for other than intended use.
14. Use only cookware that is suitable for electric ranges. Make sure the cookware has a flat base/cooking surface. See figure on page 4 for more information.
15. Place a heat resistant pad or mat under the unit before using to prevent possible heat damage to counter or table top.
16. Any maintenance other than cleaning should be performed only by an authorized service repair station.
17. Clean the appliance regularly as a build-up of grease poses a fire hazard.
18. Never cook food directly on the burners. Always use proper cookware.
19. Do not attempt to cut food in cookware while on the heated burners.
20. Do not leave cookware on hot burners unattended. Close supervision is necessary when using this product.
21. Notice: This double burner range is manufactured with one low wattage burner and one higher wattage burner. The lower wattage burner will not glow bright red like the other burner. Please note that this is not a malfunction.

SAVE THESE INSTRUCTIONS

SHORT CORD INSTRUCTIONS

1. A short power-supply cord is provided to reduce risk resulting from becoming entangled in or tripping over a longer cord.
2. Longer extension cords are available and may be used if care is exercised in their use.
3. If a longer extension cord is used:
 - a. The marked electrical rating of the extension cord should be at least as great as the electrical rating of the appliance.
 - b. The longer cord should be arranged so that it will not drape over the counter top or tabletop where it can be pulled by children or tripped over unintentionally.

POLARIZED PLUG

This appliance has a **polarized plug** (one blade is wider than the other); follow the instructions below:

To reduce the risk of electric shock, this plug is intended to fit into a polarized outlet only one way. If the plug does not fit fully into the outlet, reverse the plug. If it still does not fit, contact a qualified electrician. Do not attempt to modify the plug in any way.

This appliance is for household use only.

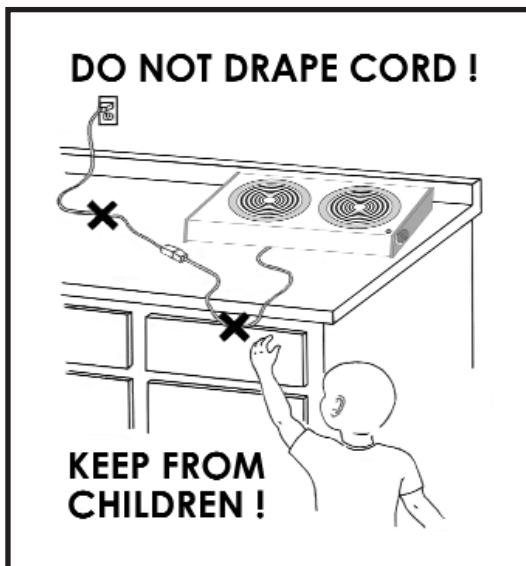

PARTS IDENTIFICATION

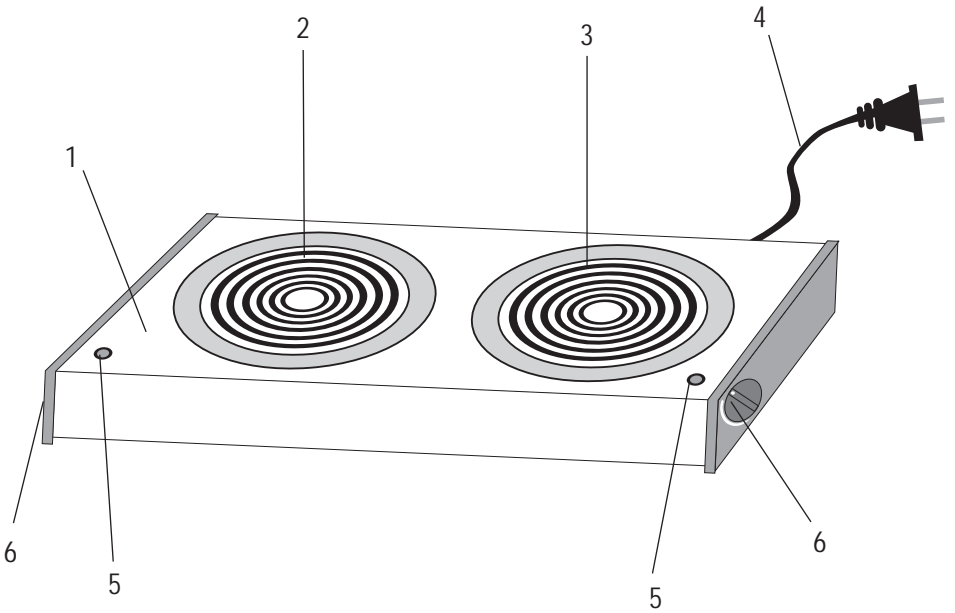

1. Burner Body
2. 440 Watt Heating Element
3. 1000 Watt Heating Element
4. Power Cord and Plug
5. Power Indicator Lights
6. Control Knobs

HOW TO USE

Before First Use:

1. Read all instructions and important safeguards.
 2. Remove all packaging materials and make sure items are received in good condition.
 3. Tear up all plastic bags as they can pose a risk to children.
 4. Place the electric burners on a flat, sturdy, heat resistant counter, or tabletop for use.
 5. Wipe burners clean with a damp cloth.
- **Do not use abrasive cleaners or scouring pads.**
 - **Do not immerse any part of this appliance or power cord in water or other liquid.**

Suitable Cookware To Use:

1. To ensure safety and maximum heat efficiency, Use only pots and pans with flat bases. See figure below.
3. Stainless steel, nonstick, heat-proof glass and heat-proof ceramic cookware are suitable to use on the electric burners.
2. The diameter of the bottom of pots and pans should be within 1 inch of the diameter of the burners' cooking surface to ensure safety.

CAUTION:

- Do not use any cookware that does not have a completely flat bottom..

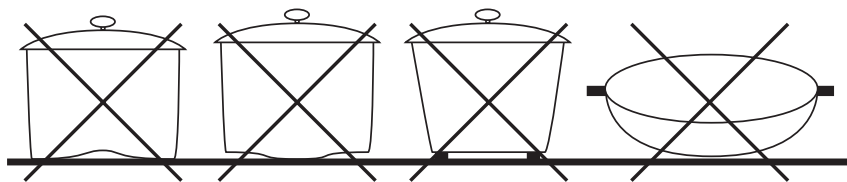

How to Use:

1. Turn the control knob to the desired level of heat. The temperature can be adjusted from low to high by turning the control knobs.
2. Place the cookware on burners.
3. When finished cooking, turn control knobs to OFF position and unplug from wall outlet. Wait until the burners have completely cooled before cleaning.

Notice:

- This double burner range is manufactured with one low wattage burner and one higher wattage burner. The lower wattage burner will not glow bright red like the other burner. Please note that this is not a malfunction.

HOW TO CLEAN

Always unplug unit and allow to cool completely before cleaning.

1. Use a damp soft sponge or cloth to clean the burners. It is ok to use a small amount of non-abrasive detergent.
 - Do not use harsh abrasive cleaners.
 - Do not immerse any part of this appliance or power cord in water or other liquid.
 - Electric burners are not dishwasher safe.

Storage:

1. Store the burners in a cool, dry place.
2. To protect the tubular heating elements, do not stack any items on burners when stored.

RECIPES

CREAMY CHICKEN WITH ANGEL HAIR PASTA

Makes 4 servings

- 4 boneless, skinless chicken breasts
- 1 cup sliced onions
- 2 shallots, sliced
- 2 tbsp olive oil
- 1/2 cup half-and-half or heavy whipping cream
- 1/4 cup finely chopped fresh tarragon
- 1 tsp salt
- 1/2 tsp pepper
- 1 tsp white wine
- 8 oz. cooked angel hair pasta

Heat olive oil in a skillet. Add chicken and cook at medium heat for 5 to 8 minutes per side or until golden brown. Remove chicken from skillet. Do not turn off the range. Add sliced onions, shallots and wine to skillet. Cook about 5 minutes.

Place chicken in the skillet. Fold chicken cutlets with half-and-half, salt, pepper and tarragon. Add 1/2 cup chicken stock if more juice is desired. Cook for an additional 5 to 7 minutes. Serve chicken and sauce over cooked angel hair pasta.

LIME FLAVORED POTATO WEDGES

Makes 4 servings

- 2 Russet potatoes
- 1/4 cup mayonnaise
- 1 tsp salt
- 1 tbsp fresh lime juice
- 1 tsp freshly ground black pepper
- 1 tbsp vegetable oil

Cut potatoes into 1/2" thick wedges. Pat dry with paper towels. Heat vegetable oil in skillet at medium heat. Add potato wedges. Pan fry potatoes for about 10 minutes or until both sides golden. Mix mayonnaise and lime juice to coat the potatoes. Cook for another 5 minutes or until done.

RECIPES

MARINATED SPICY SKIRT STEAK

Makes 4 servings

1-1/2 lbs. Skirt steak, trim off fat

Steak Marinade:

- 2 tsp cooking wine
- 2 tbsp olive oil
- 2 tsp brown sugar
- 2 tsp fresh ground pepper
- 2 jalapeños
- 2 tsp ground cinnamon
- 2 tbsp lime juice
- 1 tbsp light soy sauce
- 1/4 cup finely chopped garlic
- 1 cup finely chopped, seedless tomato
- 1/2 cup beef stock

Pat the skirt steak dry and trim off fat. Marinate steak with all ingredients in a large bowl and refrigerate for 2 hours. Heat skillet over high heat. Cook steak for 3 minutes per side. Add chopped garlic and tomato to skillet. Cook a few more minutes and add beef stock to simmer for about 2 minutes. When done, remove steak to cutting board and reserve the sauce in a small bowl. Slice steak thinly across the grain. Serve hot and top with sauce and chopped fresh cilantro.

SANTA FE CHICKEN WITH SALSA

Makes 4 servings

- 4 skinless, boneless chicken breasts
- 1/2 tsp red chili powder and salt
- 1 tbsp. cumin
- 2 tbsp lemon juice
- 1/2 tbsp grated fresh ginger
- 1/2 jar of medium spicy salsa

Pat chicken dry and marinate with lemon juice, ginger, garlic and chili powder. Bring skillet to medium heat. Cook chicken for 15 minutes per side or until cooked. Slice the chicken into strips and serve with salsa, freshly chopped cilantro and steamed corn.

RECIPES

GRILLED HERB-STUFFED CHICKEN

Makes 2 servings

- 1 quartered chicken with skin (including 2 legs and 2 thighs with wings)
- 1 tsp salt
- 2 tbsp finely chopped chives
- 1 tbsp finely chopped fresh rosemary
- 1 tsp ground black pepper
- 1/2 tsp dried thyme
- 2 tbsp melted vegetable margarine
- 1 tbsp light sour cream

Marinate chicken with salt, wine and black pepper and place in refrigerator for 30 minutes. Combine stuffing ingredients (chives, fresh rosemary, black pepper, dried thyme, melted vegetable margarine, sour cream) in a medium bowl, stir well. Take one spoon of stuffing mixture and stuff it under the skin of chicken. Leave the skin attached to chicken. Cook on medium heat about 10 minutes for each side. Turn to low heat and cook until the chicken is fully done. Serve hot with pasta.

MU-SHU PORK WRAP

- 1/2 lb. lean pork tenderloin
- 2 eggs, lightly beaten
- 1 medium carrot
- 2 green onions
- 5 oz. bamboo shoots
- 1/4 cup soaked black mushrooms
- 2 tbsp Hoisin sauce
- 1/2 tbsp sugar
- 1 tsp soy sauce
- 4 warm Mandarin flour skins
- 2 tbsp vegetable oil

Cut pork and vegetables into matchstick shreds. Marinate pork with soy sauce and cornstarch. Heat vegetable oil in large skillet over high heat. Stir fry green onions and pork for about 3 minutes until the pork turns white, then remove cooked pork. Add the rest of vegetables to the skillet and stir fry for about 5 to 7 minutes then pour in the beaten eggs. Combine pork and vegetables. Add 1 more tsp of vegetable oil if needed. Season with Hoisin sauce, salt and sugar to taste, then stir fry for another minute, or until ingredients are fully cooked. Wrap Mu-Shu with warm, thin flour tortilla and serve hot.

LIMITED WARRANTY

Aroma Housewares Company warrants this product free from defects in material and workmanship for one year from provable date of purchase in continental United States.

Within this warranty period, Aroma Housewares Company will repair or replace, at its option, defective parts at no charge, provided the product is returned, freight prepaid with proof of purchase and U.S. \$8.00 for shipping and handling charges payable to Aroma Housewares Company. Before returning an item, please call the toll free number below for return authorization number. Allow 2-4 weeks for return shipping.

This warranty does not cover improper installation, misuse, abuse or neglect on the part of the owner. Warranty is also invalid in any case that the product is taken apart or serviced by an unauthorized service station.

This warranty gives you specific legal rights and which may vary from state to state and does not cover areas outside the United States.

AROMA HOUSEWARES COMPANY
6469 Flanders Drive
San Diego, California 92121
1-800-276-6286
M-F, 8:30 AM - 5:00 PM, Pacific Time
Website: www.aromaco.com