

AROMA[®]

Twisty Treat
Soft Serve Ice Cream Maker

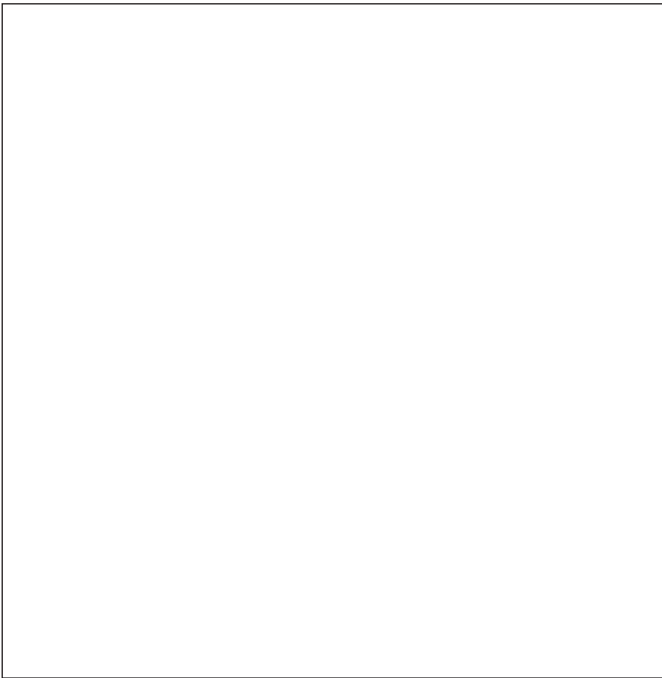

**Instruction Manual
& Recipe Guide**

Model AIC-107

Congratulations on your purchase of the **AROMA** Twisty Treat Soft Serve Ice Cream Maker. Making rich, delicious soft ice cream has never been easier - just place the ingredients in the frozen canister and turn the unit on! The authentic ice-cream shop style dispenser lets you make true twisty cones.

Easy to make recipes are included in this manual. Additional soft serve, frozen yogurt or sorbet recipes may be created with this machine, although the results may vary by recipe.

To ensure your safety and enjoyment of this product, please read all instructions carefully before using this product.



Published By:

Aroma Housewares Co.
6469 Flanders Drive
San Diego, CA 92121
U.S.A.
1-800-276-6286
www.aromaco.com

© 2006 Aroma Housewares Company. All rights reserved.

IMPORTANT SAFEGUARDS

Basic safety precautions should always be followed when using electrical appliances, including the following:

1. To protect against electric shock, do not immerse any part of this appliance in water or any other liquid.
2. This appliance is not intended for use by young children without supervision. Children should be supervised at all times while using this appliance.
3. Never leave this appliance unattended while in use.
4. Do not operate the ice cream maker when empty. Always have ice cream mixture in the unit when turned on.
5. Switch off and remove the plug from the wall outlet when not in use, before assembling or disassembling parts and before cleaning.
6. To unplug, grasp plug at the base and pull from outlet. Do not grasp, pull on, or carry by the power cord.
7. Avoid contact with moving parts. Keep hands, hair, clothing, spatulas, and other utensils away during operation to prevent injury and/or damage to the appliance.
8. Do not operate the appliance with a damaged cord or plug or after it malfunctions, has been dropped or damaged in any manner. Return appliance to the nearest authorized service facility for examination, repair, or adjustment.
9. Do not place complete unit in the refrigerator or freezer. Only the canister is freezer-safe.
10. Make sure that the canister and lid cover are fitted correctly before operating this appliance.
11. Do not use outdoors.
12. Store unit in a dry location.
13. Do not let cord hang over the edge of a table or counter, or touch hot surfaces.
14. Do not operate or place any part of this appliance on or near hot surfaces such as on a gas or electric burner or in a heated oven.
15. The use of attachments or accessories not recommended or sold by the manufacturer may cause fire, electric shock, or injury.
16. Always operate on a sturdy, level surface. Do not operate this appliance in a sink, on a drain board, or any other uneven surface.
17. Do not use this appliance for anything other than its intended use. This product is intended for household use only.
18. Do not attempt to repair, disassemble, or modify this appliance in any way. It contains no user serviceable parts.

SAVE THESE INSTRUCTIONS

SHORT CORD INSTRUCTIONS

1. A short power-supply cord is provided to reduce the risk of becoming entangled in or tripping over a longer cord.
2. Longer extension cords are available and may be used if care is exercised in their use.
3. If a longer extension cord is used:
 - a. The marked electrical rating of the extension cord should be at least as great as the electrical rating of the appliance.
 - b. The longer cord should be arranged so that it will not drape over the counter top or tabletop where it can be pulled by children or tripped over unintentionally.

POLARIZED PLUG

This appliance has a polarized plug (one blade is wider than the other); follow the instructions below:

To reduce the risk of electric shock, this plug is intended to fit into a polarized outlet only one way. If the plug does not fit fully into the outlet, reverse the plug. If it still does not fit, contact a qualified electrician. Do not attempt to modify the plug in any way.



This appliance is for household use only.

PARTS IDENTIFICATION

1. Lid
2. On/Off Switch
3. Gear Unit
4. Mixing Paddle
5. Canister
6. Body
7. Tap Dispenser
8. Base
9. Removable Drip Tray

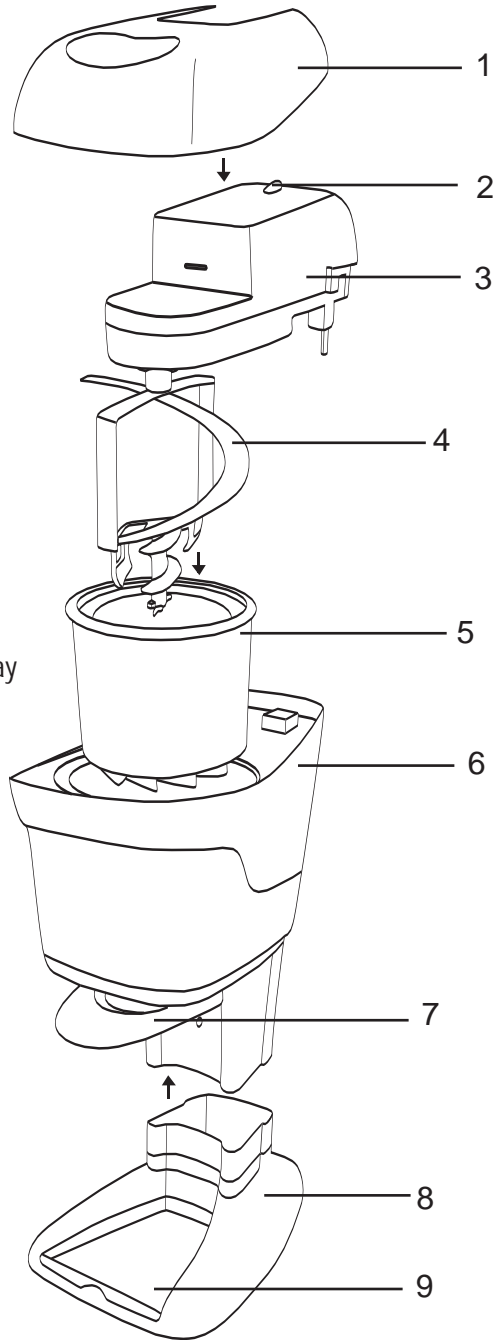



The following three steps are VERY IMPORTANT in making soft serve ice cream. *Please read and follow all instructions carefully - or there is a chance that your ice cream will not turn out!*

- 1) Make sure that the mixing canister is placed in the freezer for at least 24 hours prior to making ice cream. Freezer should be set at 0°F.
- 2) It is best to prepare the ice cream recipe a day before you plan to use your ice cream maker. Placing it, covered, in the refrigerator for 12-24 hours will ensure that it is completely chilled.
- 3) Only take out the canister and ice cream mixture when you are ready to make ice cream. Do not rinse the canister. Rinsing or allowing to sit out for too long will cause them to warm up and will affect the results of your ice cream making.

BEFORE FIRST USE

Before First Use:

1. Read all instructions and important safeguards.
2. Remove all packaging materials and make sure items have been received in good condition.
3. Tear up all plastic bags, as they can pose a risk to children.
4. Wash the canister, lid, and mixing paddle in warm, soapy water. These parts are NOT dishwasher safe.
5. Rinse and dry all parts thoroughly.
6. Wipe the exterior body and gear unit of the appliance with a damp cloth. Do not immerse in water.
7. Place clean, dry canister in the back of your freezer. It must freeze for a minimum of 24 hours before you may begin to make soft ice cream.
 - Do not use abrasive cleaners or scouring pads.
 - Do not immerse the body, cord, gear unit or plug in water at any time.

IMPORTANT FIRST STEPS

Chilling the Canister

Once the canister has been cleaned and is completely dry, place the canister in the freezer for a minimum of 24 hours. This allows the canister to become cold enough to freeze the soft serve mixture. It is recommended to keep the canister wrapped in a plastic bag and placed in the back of your freezer when not in use. This ensures that it is available for immediate use the next time you would like to make soft ice cream.

Preparing the Mixture

Select your favorite recipe, prepare ingredients per recipe instructions. In order to achieve a soft-serve consistency, it is important that the ingredients be VERY COLD before you begin to mix. Chill the mixture in the refrigerator overnight or for a minimum of 4 hours prior to mixing, or you may place the mixture in the freezer for 15-30 minutes to ensure that it is completely chilled.

When both the canister and mixture are fully chilled, you may begin to make soft serve ice cream.

HOW TO USE

Assembling the Unit

1. Refer to the Parts Identification page for a more detailed diagram.
2. Fit the body of the soft serve maker onto the base.
3. Just before you are ready to make ice cream, remove the chilled canister from freezer and immediately place into the body. Do not rinse the canister or allow it to sit out on the counter, as this may cause the temperature of the canister to rise substantially. Turn the canister slightly while pressing down to ensure that it fits properly into the machine.
4. Attach the mixing paddle to the gear unit (Figure 1) and place over the top of the unit.
5. Fit the tap dispenser into the body (Figure 2). Hold the tap dispenser and lift up so the tap dispenser fits into the hole. Rotate the tap dispenser counterclockwise until it locks into place. Push the tap dispenser handle DOWN to ensure it is in the closed position.
6. Place the lid on the top of the unit, making sure that it locks into place.

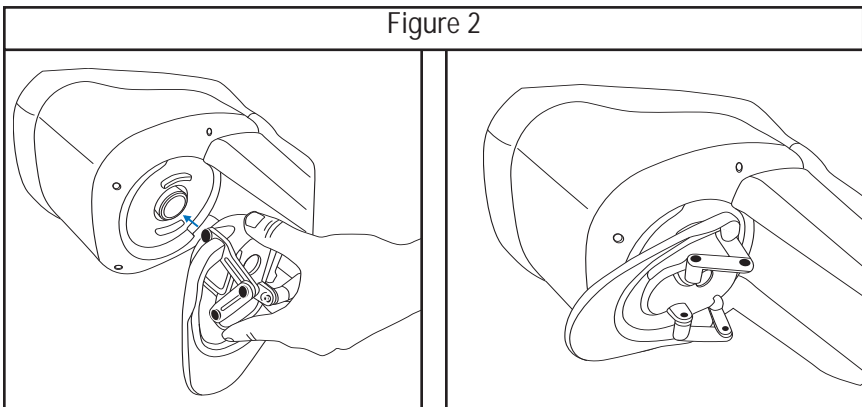
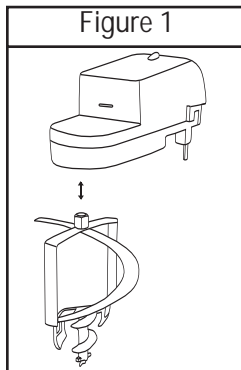

HOW TO USE

Mixing the Soft Serve

1. Place the assembled soft serve maker on a sturdy, level surface and plug into a power cord outlet. It is important to begin the mixing process immediately after removing the canister from the freezer and assembling the appliance, to avoid letting the canister warm up.
2. With the chilled ice cream mixture ready, press the ON switch. The paddle will begin to rotate.
3. Making sure that the dispenser handle is in the DOWN (closed) position, pour the chilled mixture into the canister through the opening in the lid.
4. Allow the mixture to churn for approximately 20-40 minutes until it has reached soft-serve consistency. The churning time will vary depending on the recipe being made, the temperature of the freezer where the canister was frozen, and the length of time the canister and ice cream mixture were allowed to chill.
5. Turning off the appliance at any time during the churning process may cause the mixture to harden and restrict the operation of the mixer.
6. Once the mixture has reached the desired consistency, hold a cone or small bowl under the dispenser and lift up on the handle. Do not turn off the power. The soft serve ice cream will dispense as the motor churns.
7. To stop the flow of ice cream, press down on the dispenser handle.
8. If all of the ice cream does not dispense from the canister, as may occur when the mixture churns too long and becomes very thick, simply turn off the motor and remove the lid (see Figure 3 below for instructions on removing the lid), then scoop out the remainder of the contents with a spoon.
9. When all of the ice cream has been dispensed, make sure to press down on the dispenser handle to close the tap. Then switch the power to OFF.

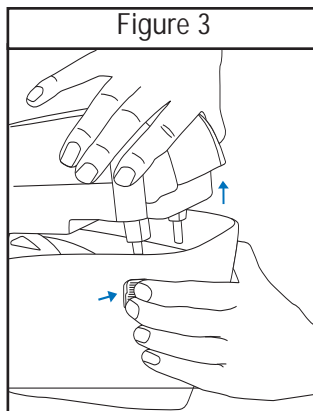

HELPFUL TIPS

- We recommend that you wrap the canister in a plastic bag and place it in the back of your freezer after you have finished using it and once it has been cleaned. This is a great way to make sure that it is ready for immediate use the next time you make soft serve ice cream. Wrapping it in a plastic bag helps to protect it from freezer burn.
- When removing the frozen canister from the freezer, DO NOT RINSE the canister or allow it to sit out in room temperature for more than a few minutes before you begin to make your ice cream. It is very important that the canister be as cold as possible during the mixing process in order to achieve a soft-serve consistency.
- It is recommended that you make the ice cream mixture a day ahead, cover it and place it in the refrigerator. The mixture will then be able to cool completely and expand. Pre-chilling any ice cream recipe is necessary for achieving the best results.
- The richer the cream you use, the richer the ice cream will be. Heavy whipping cream is suggested for the creamiest, smoothest ice cream. Light cream can also be substituted for cream, but the texture and taste of the ice cream may change.
- Artificial sweeteners may be substituted for sugar. Use the following proportions for reference:

1	packet of sweetener = 2 tsp. sugar
6	packets = 1/4 cup
8	packets = 1/3 cup
12	packets = 1/2 cup
- You may taste the mixture to adjust the amount of sugar to be added. Note that the actual ice cream will taste less sweet than the mixture.

HOW TO CLEAN

Always unplug unit and allow to cool completely before cleaning.

1. Turn the power switch to the OFF position and unplug unit from the wall outlet before disassembling or cleaning.
2. Remove the lid by pressing the self-lock at the rear and lifting upward. See Figure 3 on page 6 for a diagram.
3. Remove the mixing paddle and motor unit by lifting upward.
4. Remove the dispenser tap by turning it to the left and then pulling straight down. See Figure 2 on page 5 for a diagram.
5. Remove canister by pushing it up from underneath.
6. Remove the mixing paddle from the gear unit. See Figure 1 on page 5 for a diagram.
7. Wash the lid, dispenser tap, mixing paddle and canister in soapy water.
8. Rinse and dry all parts thoroughly.

NOTE: Do not immerse the gear unit or the body of the ice cream maker in water. Do not place any parts of the soft serve ice cream maker in the dishwasher. This appliance is not dishwasher safe.

9. Wipe the exterior of the ice cream maker and the gear unit with a soft damp cloth. Do not submerge in water. Dry thoroughly. Sharp utensils, scouring pads, or abrasive detergents may cause damage to this appliance.

Helpful Hint: Wrapping the canister in a plastic bag and placing it back into the freezer after cleaning is a great way to have it ready for immediate use the next time you'd like to make soft serve ice cream.

RECIPES

Easy Vanilla Soft Serve

- 2/3 cup whole milk
- 1/2 cup granulated sugar
- 1 1/3 cup heavy cream
- 1 teaspoon pure vanilla extract

Place the milk and the sugar in a mixing bowl. Using a hand mixer on low speed for 1 to 2 minutes, mix together the milk and sugar. You may also use a whisk to mix until all of the sugar is dissolved. Stir in the heavy cream and the vanilla. Cover the bowl with plastic wrap and refrigerate overnight, or for a minimum of 4 hours.

When mixture has chilled and mixing canister is completely frozen, follow the mixing instructions in the How To Use section of this manual.

Easy Chocolate Soft Serve

- 1/3 cup unsweetened cocoa powder
- 1/3 cup granulated sugar
- 1/4 cup firmly packed brown sugar
- 2/3 cup whole milk
- 1 1/3 cup heavy cream
- 1/2 teaspoon pure vanilla extract

Place the cocoa and the sugars in a medium bowl and stir with a wire whisk to combine and remove any lumps. Add the whole milk and, using a hand mixer on low speed for 1 to 2 minutes, mix together the milk, cocoa, and sugar mixture. You may also use whisk to mix until the cocoa and sugar are completely dissolved. Stir in the heavy cream and vanilla. Cover the bowl with plastic wrap and refrigerate overnight, or for a minimum of 4 hours.

When the mixture has chilled and mixing canister is completely frozen, follow the mixing instructions in the How To Use section of this manual.

RECIPES

Easy Strawberry Soft Serve

- 5 1/4 oz. red strawberries (very ripe) or frozen strawberries, thawed
- 1/2 cup granulated sugar
- 1/8 teaspoon pure vanilla extract
- 1/2 cup whole milk
- 1 cup heavy cream

Place strawberries, granulated sugar, vanilla, and whole milk in a blender jar or food processor and blend on high speed until completely smooth and homogenous, about 60 seconds. Pour into a bowl and stir in heavy cream. Cover bowl with plastic wrap and refrigerate overnight, or for a minimum of 4 hours.

When the mixture has chilled and the mixing canister is completely frozen, follow the mixing instructions in the How To Use section of this manual.

LIMITED WARRANTY

Aroma Housewares Company warrants this product free from defects in material and workmanship for one year from the provable date of purchase in the continental United States.

Within this warranty period, Aroma Housewares Company will repair or replace, at its option, defective parts at no charge, provided the product is returned, freight prepaid with proof of purchase and U.S. \$10.00 for shipping and handling charges payable to Aroma Housewares Company. Before returning an item, please call the toll free number below for a return authorization number. Allow 2-4 weeks for return shipping.

This warranty does not cover improper installation, misuse, abuse or neglect on the part of the owner. Warranty is also invalid in any case that the product is taken apart or serviced by an unauthorized service station.

This warranty gives you specific legal rights and which may vary from state to state and does not cover areas outside the United States.

AROMA HOUSEWARES COMPANY

6469 Flanders Drive

San Diego, California 92121

1-800-276-6286

M-F, 8:30 AM - 5:00 PM, Pacific Time

Website: www.aromaco.com