

AROMA[®]

Old Fashioned Ice Cream Freezer



Instruction Manual & Recipe Guide

Model AIC-305EM

Congratulations on your purchase of the **AROMA** Ice Cream Freezer. You can now make your own rich and creamy homemade ice cream or frozen yogurt. You can also make your own favorite, healthy and delicious sherbet, sorbet, ice and frozen drinks fast and easy. Enjoy your new Ice Cream Freezer!

Please read all instructions carefully before using this product.



Published By:

Aroma Housewares Co.
6469 Flanders Drive
San Diego, CA 92121
U.S.A.
1-800-276-6286
www.aromaco.com

© 2005 Aroma Housewares Company. All rights reserved.

IMPORTANT SAFEGUARDS

Basic safety precautions should always be followed when using electrical appliances, including the following:

1. Read all instructions.
2. Do not touch hot surfaces. Use handles or knobs.
3. To protect against electrical shock, do not immerse cords, plugs or the electric motor in water or other liquid.
4. Close supervision is necessary when any appliance is used by or near children.
5. Unplug from outlet when not in use, before cleaning, and before putting on or taking off parts.
6. Avoid contacting moving parts. Keep fingers, hair, clothing, as well as utensils away during operation.
7. Do not operate any appliance with a damaged cord or plug or after the appliance malfunctions, or has been damaged in any manner. Return appliance to the nearest authorized service facility for examination, repair or adjustment.
8. The use of accessory attachments not recommended by the appliance manufacturer may cause injuries.
9. Do not use outdoors.
10. Do not let cord hang over edge of table or counter, or touch hot surfaces.
11. Do not use the appliance for other than intended use.
12. Do not place this appliance on or near a hot gas or electric burner, or in a heated oven.
13. To disconnect power, press switch to OFF position and then remove plug from wall outlet.
14. Never operate ice cream maker dry. Always have ice cream mixture in the container while plugged in.
15. Do not use hot oil or liquids in ice cream maker. Always chill mixtures before churning.

SAVE THESE INSTRUCTIONS

SHORT CORD INSTRUCTION

1. A short power-supply cord is provided to reduce risk resulting from becoming entangled in or tripping over a longer cord.
2. Longer extension cords are available and may be used if care is exercised in their use.
3. If a longer extension cord is used:
 - a. The marked electrical rating of the extension cord should be at least as great as the electrical rating of the appliance.
 - b. The longer cord should be arranged so that it will not drape over the counter top or tabletop where it can be pulled by children or tripped over unintentionally.

POLARIZED PLUG

This appliance has a **polarized plug** (one blade is wider than the other); follow the instructions below:

To reduce the risk of electric shock, this plug is intended to fit into a polarized outlet only one way. If the plug does not fit fully into the outlet, reverse the plug. If it still does not fit, contact a qualified electrician. Do not attempt to modify the plug in any way.



This appliance is for household use only.

PARTS IDENTIFICATION

1. Hand Crank
2. Electric Motor
3. Latch
4. Power Cord
5. Wooden Bucket
6. Stabilizing Ring
7. Canister Lid
8. Canister Lid Cap
9. Ice Cream Canister
10. Plastic Stirrer
11. Dasher

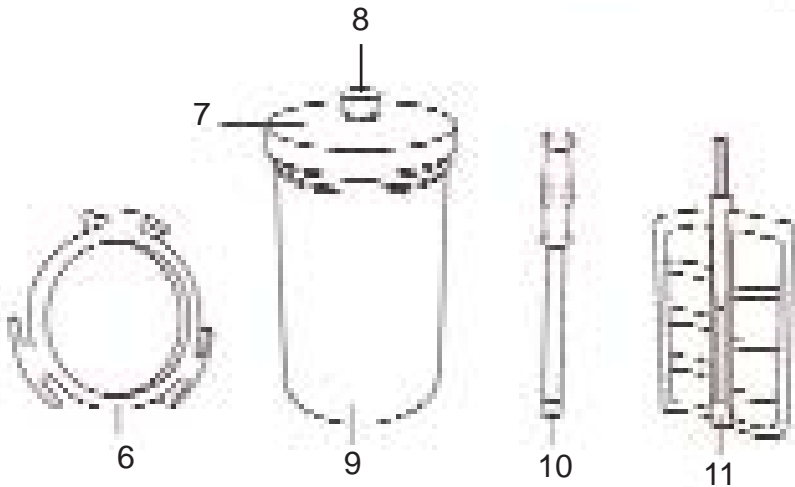
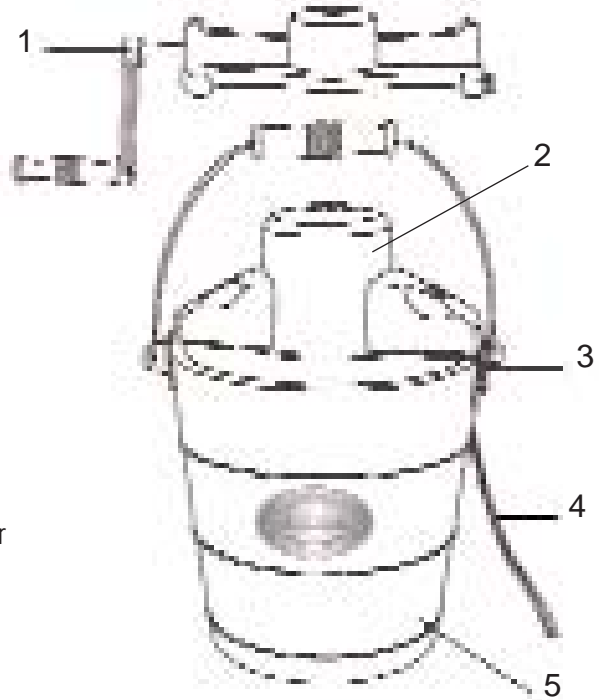

HOW TO USE

Before First Use:

1. Read all instructions and important safeguards.
 2. Remove all packaging materials and make sure items have been received in good condition.
 3. Tear up all plastic bags, as they can pose a risk to children.
 4. Wash the lid, freezer canister and all accessories in warm soapy water.
 5. Rinse and dry all parts thoroughly.
 6. Wipe electric motor with a damp cloth.
 7. Pour water (about 2/3 full) into the wooden bucket and leave for one and a half hours. This will give it a chance to swell up so that the salt/ice mixture will not leak out during the freezing process.
- Do not use abrasive cleaners or scouring pads.
 - Do not immerse the base, cord or plug in water at any time.

How to Use:

1. Select your favorite recipe, prepare ingredients per recipe instructions.
2. Pour chilled ice cream mixture into chilled ice cream canister (**fill no more than 2/3 full as mixture will expand during freezing process**).
3. Insert the dasher and make sure the bottom of dasher is fixed in the center of the bottom of the canister. (Figure 1)
4. Place the lid on the canister. (Figure 2)
5. Place the plastic stabilizing ring into the wooden bucket. (Figure 3]

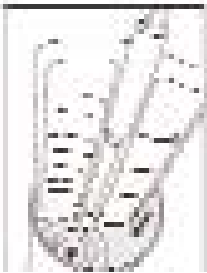

Figure 1



Figure 2

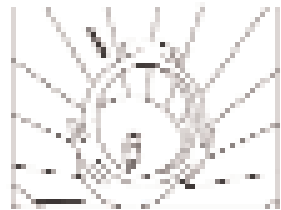

Figure 3

HOW TO USE

7. Place the canister in the wooden bucket and make sure it engages the cone in the center of the bucket. (Figure 4)



Figure 4

8. Slide the rectangular end of the hand crank or electric motor into the rectangular hole on the rim of the bucket (figure 5a). The opposite end of the crank will drop into the open end, where the latch is (figure 5b). Gently lift the latch so that the wire goes over the rounded end of the hand crank or motor (you may need to rotate the canister by hand so that the lid fits into the motor/hand crank)(Figure 5c).

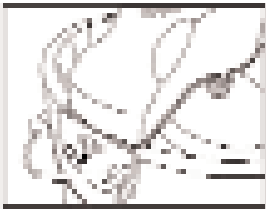

Figure 5a

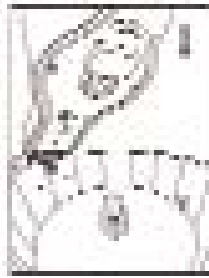

Figure 5b



Figure 5c

9. Plug the power cord into outlet if you are using the electric motor.
10. Fill the wooden bucket with ice to the top of the canister.
11. Crank or run the motor for about 2 to 3 minutes so that the canister chills evenly.
12. Add 2 cups of rock salt to the top of the ice. As the ice melts down 2 to 3 inches, add more ice and 2 more cups of rock salt.
13. Unplug and remove motor drive once ice cream has churned about 40 minutes, or once the motor has stopped (if the motor has stopped prematurely, turn it off, break up any ice blockages with the plastic stirrer and start again).
14. Clear the ice and salt away from the top of the ice cream canister. Wipe carefully to remove the salt and water before removing the cover.
15. Take the dasher out and scrape off excess ice cream with a wooden spatula.
16. Transfer to a freezable container and freeze or serve straight from the canister.

HOW TO USE

NOTE:

- Make sure the ice that you put into the bucket is broken into small, coarse pieces. You may use a mallet or hammer to break into smaller pieces if needed.
- As the canister turns, stir and mix the salt and ice together. Use the plastic stirrer every 10-15 minutes while the ice cream maker is in use.
- To avoid ice cream seeping out of the canister, do not lay the canister flat when storing in a freezer.
- If ice cream is too soft, put it in a freezable container and refrigerate for an hour or two. You may also attach the hand crank unit and crank the ice cream to the desired consistency.

WARNING:

- Do not plug the drain hole on the side of the wooden bucket. This is for draining excess salt water and should be kept open at all times.
- Should electric motor stop before churning is complete (approximately 40 minutes), check to see if large ice cubes are jammed against the canister. If so, turn off motor and remove jammed ice.
- The electric motor will automatically shut off if the ingredients in the canister are too hard for the paddle to turn. The ice cream maker will function normally again once the hard ingredients are removed from the canister.

HELPFUL TIPS

- For ice cream recipes that require pre-cooking, it is recommended that you make the mixture a day ahead. The mixture will then be able to cool completely and expand. Pre-chilling any ice cream recipe is suggested for achieving the best results.
- The richer the cream you use, the richer the ice cream will be. Whipped heavy cream is suggested for the creamiest, smoothest ice cream. Milk can also be substituted for cream, but the texture and taste of the ice cream may change. You might also consider using a combination of milk and cream for healthier ice cream.
- Artificial sweeteners may be substituted for sugar. Use the following portion as a reference:
 - 1 packet of sweetener = 2 tsp. sugar
 - 6 packets = 1/4 cup
 - 8 packets = 1/3 cup
 - 12 packets = 1/2 cup
- If the recipe calls for alcohol, add it during the last few minutes of the freezing cycle.
- You may taste the mixture to adjust the amount of sugar to be added. Note that the actual ice cream will taste less sweet than the mixture.

HOW TO CLEAN

Always unplug unit and allow to completely cool before cleaning.

1. Wipe electric motor with a slightly damp cloth to remove debris.
 2. Clean wooden bucket with a soapy sponge thoroughly, to remove the salt-water residue. Rinse and dry to ensure the salt does not corrode the metal parts.
 3. Wash canister, lid and dasher with soapy water and dry thoroughly. Do not replace the lid until the ice cream canister is completely dry.
- Do not use harsh abrasive cleaners.
 - This appliance and accessories are NOT dishwasher safe.
 - Do not freeze canister when wet.

RECIPES

Peanut Butter Chocolate Chip Ice Cream

3-1/4 cup granulated sugar
2 tbsp cornstarch
1/2 tsp salt
1 tsp vanilla
7 cups milk
5 eggs, beaten
2-3/4 cups heavy cream
1-1/2 cups half and half
2 cups chocolate chips
1/2 cup peanut butter or 1 cup peanut butter chips, melted

Mix the sugar, cornstarch and salt in a large saucepan. Over medium heat, slowly stir in the milk, stirring constantly. Very slowly, add the beaten eggs and continue to stir. Reduce heat to low and cook until mixture thickens slightly. Slowly stir in peanut butter and whisk until all peanut butter is combined and mixture is smooth. Slowly add vanilla, half and half, and heavy cream. Pour into a large glass bowl and refrigerate for 2-4 hours or until mixture has chilled. Remove from refrigerator and add chocolate chips. Pour mixture into the mixing canister and follow directions in the "How to Use" section, pages 4 to 7.

Mixed Berry Sorbet

2 ,12oz bags of frozen mixed berries
3 cups granulated sugar
1/3 cup fresh lemon juice
5 cups cran-raspberry juice
2 cups apple juice
2 cups water

Finely purée the berries in a blender with apple juice and water. Strain mixture into a large saucepan to remove seeds. Discard seeds. Add sugar to the seedless mixture, bring to a boil for 3-4 minutes. Stir in remaining juices. Pour into a large glass bowl and refrigerate 2-4 hours. Pour mixture into mixing canister and follow directions in the "How to Use" section, pages 4 to 7.

RECIPES

Vanilla Ice Cream

3-1/4 cup granulated sugar
2 tbsp cornstarch
1/2 tsp salt
1-1/2 tbsp vanilla
7 cups milk
5 eggs, beaten
2-3/4 cups heavy cream
1-1/2 cups half and half

Mix the sugar, cornstarch and salt in a large saucepan. Over medium heat, slowly stir in the milk, stirring constantly. Very slowly, add the beaten eggs and continue to stir. Reduce heat to low and cook until mixture thickens slightly. Slowly add vanilla, half and half, and heavy cream. Pour into a large glass bowl and refrigerate for 2-4 hours or until mixture has chilled. Remove from refrigerator. Pour mixture into the mixing canister and follow directions in the "How to Use" section, pages 4 to 7.

Pineapple Sorbet

2 ,12oz bags of frozen pineapple
3 cups granulated sugar
1/3 cup fresh lemon juice
6 cups pineapple juice
1 cups apple juice
2 cups water

Finely purée the pineapple in a blender with juice and water. Strain mixture into a large saucepan for a smooth consistency. Add sugar to the mixture and bring to a boil for 3-4 minutes. Stir in remaining juice. Pour into a large glass bowl and refrigerate 2-4 hours. Pour mixture into mixing canister and follow directions in the "How to Use" section, pages 4 to 7.

RECIPES

Chocolate Ice Cream

- 3-1/4 cup granulated sugar
- 2-1/2 tsp cornstarch
- 1/2 Salt
- 7-1/2 cups milk
- 5 eggs, beaten
- 7-1/2 squares semi-sweet chocolate, melted
- 1-2/3 cups half and half
- 2-1/2 cups whipping cream
- 1-1/2 tbsp vanilla extract

Mix the sugar, cornstarch and salt in a large saucepan. Over medium heat, slowly stir in the milk, stirring constantly until the mixture begins to simmer. Very slowly, add the beaten eggs and continue to stir. Reduce heat to low and cook until mixture thickens slightly. Slowly stir in the melted chocolate and whisk until all chocolate is combined and mixture is smooth. Slowly add vanilla, half and half, and heavy cream. Pour into a large glass bowl, cover and refrigerate for 2-4 hours or until mixture has chilled. Pour mixture into the mixing canister and follow directions in the "How to Use" section, pages 4 to 7.

Rocky Road Ice Cream

- 3-1/4 cup granulated sugar
- 1/2 Salt
- 2-1/2 cups milk
- 7-1/2 squares semi-sweet chocolate
- 2-1/2 cups half and half
- 5 cups whipping cream
- 1-1/2 tbsp vanilla extract
- 2-1/2 cups mini marshmallows
- 2-1/2 cups chocolate chips
- 1-1/4 cups chopped pecans

Mix the milk and chocolate in a large saucepan. Over medium heat, stir until the chocolate is completely melted. Remove from heat and slowly add sugar and salt, mixing well, until dissolved. Stir in the remaining ingredients, then cover and refrigerate for about 30 minutes or until mixture has chilled. Pour mixture into the mixing canister and follow directions in the "How to Use" section, pages 4 to 7.

RECIPES

Strawberry Sherbet

2 ,12oz bags of frozen strawberries
2-1/2 cups granulated sugar
7 tsp fresh lemon juice
2-1/2 egg whites
1-3/4 cup water
2 cups whipping cream

In a sauce pan, mix in strawberries, sugar and water. Let simmer for 5 minutes. Strain mixture for a smooth consistency and add lemon juice. Whisk until light, then fold in the whipping cream until the mixture thickens. Pour into a large glass bowl and refrigerate 1-2 hours. Pour mixture into mixing canister and follow directions in the "How to Use" section, pages 4 to 7.

For variations, you can use the same recipe and substitute the strawberries for peaches, raspberries, blueberries or any kind of frozen fruit.

No Sugar Added Chocolate Ice Cream

4 tsp plain gelatin
10 cups low fat milk
2 cups sugar free chocolate drink mix
4 cups drained yogurt (the solid half of 2 cups yogurt strained overnight)
4 tsp vanilla extract
2 tsp salt

Soften gelatin in 2 cups milk. Heat in a saucepan until gelatin dissolves. Remove from heat and place saucepan in another bowl of cold or ice water to cool mixture to room temperature. Pour mixture into a blender or food processor. Add remaining milk, chocolate drink mix, yogurt, vanilla and salt. Blend until smooth. Pour into a large glass bowl and refrigerate 1-2 hours. Pour mixture into mixing canister and follow directions in the "How to Use" section, pages 4 to 7.

LIMITED WARRANTY

Aroma Housewares Company warrants this product free from defects in material and workmanship for one year from provable date of purchase in continental United States.

Within this warranty period, Aroma Housewares Company will repair or replace, at its option, defective parts at no charge, provided the product is returned, freight prepaid with proof of purchase and U.S. \$8.00 for shipping and handling charges payable to Aroma Housewares Company. Before returning an item, please call the toll free number below for return authorization number. Allow 2-4 weeks for return shipping.

This warranty does not cover improper installation, misuse, abuse or neglect on the part of the owner. Warranty is also invalid in any case that the product is taken apart or serviced by an unauthorized service station.

This warranty gives you specific legal rights and which may vary from state to state and does not cover areas outside the United States.

AROMA HOUSEWARES COMPANY

6469 Flanders Drive

San Diego, California 92121

1-800-276-6286

M-F, 8:30 AM - 5:00 PM, Pacific Time

Website: www.aromaco.com