

AROMA®

One-Touch, 10-Cup Rice Cooker & Food Steamer



Instruction Manual

ARC-720-1G

Congratulations on your purchase of the **AROMA** Rice Cooker & Food Steamer. It will surely become one of the most useful and versatile appliances in your modern kitchen.

Please read all instructions before your first use.



Published By:

Aroma Housewares Co.
6469 Flanders Drive
San Diego, CA 92121
U.S.A.
1-800-276-6286
www.aromaco.com

© 2004 Aroma Housewares Company All rights reserved.

IMPORTANT SAFEGUARDS

1. Important: Read all instructions carefully before first use.
2. Do not touch hot surfaces. Use handles or knobs.
3. To protect against electrical shock, do not immerse cord, plug or the appliance itself in water or other liquid.
4. Close supervision is necessary when the appliance is used near children.
5. Unplug from outlet when not in use and before cleaning. Allow unit to cool before putting on or taking off parts, and before cleaning the appliance.
6. Do not operate any appliance with a damaged cord or plug or after the appliance malfunctions or has been damaged in any manner. Return appliance to the nearest authorized service facility for examination, repair or adjustment.
7. The appliance inlet must be dried before appliance is used again
8. Do not use attachments or accessories other than those supplied or recommended by the manufacturer. Incompatible parts create a hazard.
9. Do not use outdoors.
10. Do not let cord hang over edge of table or counter, or touch hot surfaces.
11. Do not place on or near a hot burner or in a heated oven.
12. Do not use the appliance for other than intended use.
13. Do not clean with metal scouring pads. Pieces can break off the pad and touch electrical parts, creating a risk of electric shock. Metal-scouring pads may also damage the finish.
14. Always unplug from the base of the wall outlet. Never pull on the cord.
15. Extreme caution should be exercised when using or moving the appliance containing hot oil or other hot liquids.
16. The rice cooker should be operated on a separate electrical circuit from other operating appliances. If the electric circuit is overloaded with other appliances, this appliance may not operate properly.
17. Store in a cool, dry place.
18. To disconnect, unplug the rice cooker from the electric outlet.
19. Do not use attachments or accessories other than those supplied or recommended by the manufacturer. Incompatible parts create a hazard.
20. Avoid sudden temperature changes when using the rice cooker.
21. Use only with 120V AC power outlet.
22. Use extreme caution when opening the lid during or after cooking. Hot steam will escape and could cause burns.
23. Use appliance on a level, dry, and heat-resistant surface.

SAVE THESE INSTRUCTIONS

ADDITIONAL IMPORTANT SAFETY INFORMATION

- Place the rice cooker on a flat, heat-resistant surface, and use it in a well-ventilated area.
- Do not place the rice cooker too close to the edge of the table or countertop as it could be knocked off.
- Extreme caution should be used if a longer cord is used. Make sure it is positioned safely so that nobody trips over it unintentionally.
- The rice cooker base and the other parts become hot. Be sure to use the handles and wear protective oven mitts or gloves.



SHORT CORD INSTRUCTIONS

1. A short power-supply cord is provided to reduce risk resulting from becoming entangled in or tripping over a longer cord.
2. Longer extension cords are available and may be used if care is exercised in their use.
3. If a longer extension cord is used:
 - a. The marked electrical rating of the extension cord should be at least as great as the electrical rating of the appliance.
 - b. The longer cord should be arranged so that it will not drape over the counter top or tabletop where it can be pulled by children or tripped over unintentionally.

POLARIZED PLUG

This appliance has a **polarized plug** (one blade is wider than the other); follow the instructions below:

To reduce the risk of electric shock, this plug is intended to fit into a polarized outlet only one way. If the plug does not fit fully into the outlet, reverse the plug. If it still does not fit, contact a qualified electrician. Do not attempt to modify the plug in any way.

This appliance is for household use only.

PARTS IDENTIFICATION

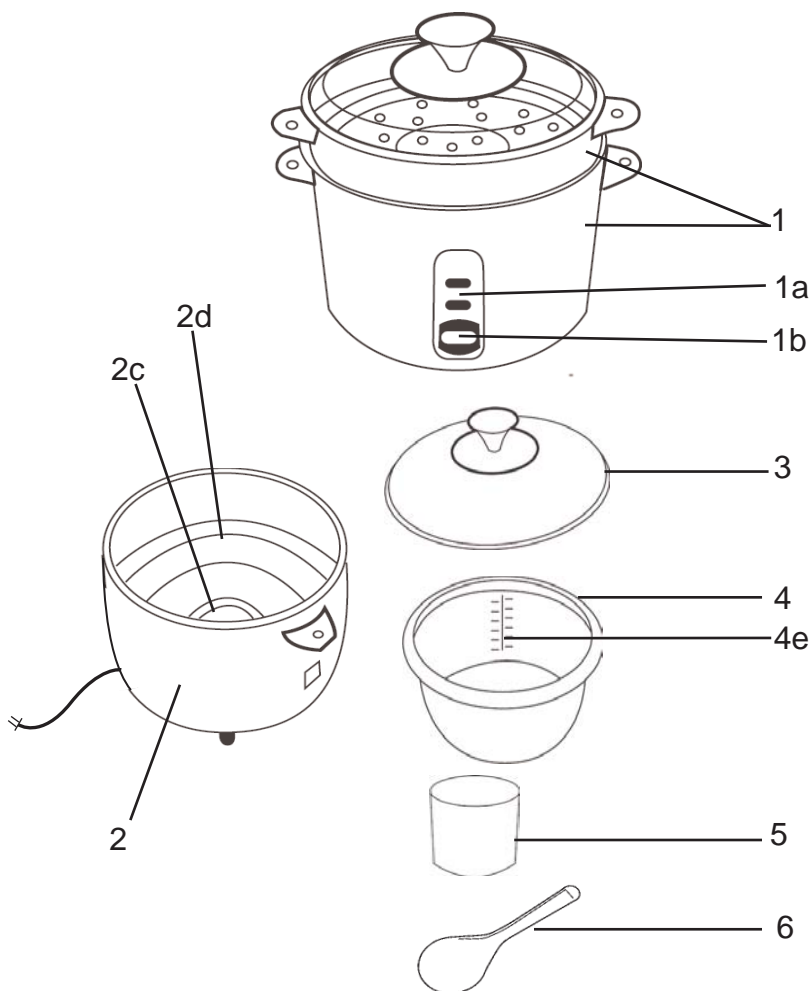

Standard Accessories:

1. Rice Cooker and Food Steamer
 - a. Cook and Warm indicator Lights
 - b. Cook Switch
2. Outer Body
 - c. Heating Plate
 - d. Thermo-Control Plate
3. Lid
4. Inner Pot
 - e. Water Measurement Lines (Liters/Cups)
5. Measuring Cup
6. Spoon

HOW TO USE

Before First Use:

1. Read all instructions and important safeguards.
 2. Remove all packaging materials and make sure items are received in good condition.
 3. Tear up all plastic bags as they can pose a risk to children.
 4. Wash accessories in warm soapy water. Rinse and dry thoroughly.
 5. Remove inner pot from rice cooker and clean with warm soapy water. Rinse and dry thoroughly before returning to cooker.
 6. Wipe body clean with a damp cloth.
- **Do not use abrasive cleaners or scouring pads.**
 - **Do not immerse the rice cooker base, cord or plug in water at any time.**

To Cook Rice:

1. Using the measuring cup provided, measure and add rice to the pot. One full level cup equals one cup.
2. Rinse rice in the inner pot until water becomes relatively clear.
3. Using the water measurement lines inside or the measuring cup, add appropriate amount of water. A rice/water measurement chart has been included on page 7.
4. For softer rice, allow rice to soak for 10-20 minutes prior to cooking.
5. Replace lid and plug power cord into outlet.
6. Press switch down, to cook mode. The cook light will illuminate. When rice is complete, it will automatically switch to warm mode and the warm light will illuminate.
7. After cooking, allow rice to stand for 5-10 minutes without removing lid. This will ensure that rice is cooked thoroughly.

To Steam Food:

1. Add the desired amount of water into the inner pot. A convenient steaming guide has been included on page 8.
2. Place steam tray on rice cooker.
3. Place food in tray and press switch to cook mode. When steaming is complete, it will automatically switch to warm mode. We recommend keeping food on warm no longer than 5-10 minutes to avoid over cooking.

CAUTION:

- Do not open lid when in use.
- If cooking pot is returned to cooker when wet, it will damage this product causing it to malfunction.

HOW TO CLEAN

Always unplug unit and allow to cool completely before cleaning.

1. Remove the inner cooking pot. Wash it in warm, soapy water using a sponge or dishcloth.
 2. Rinse and dry thoroughly.
 3. Repeat process with steam tray, and other provided accessories.
 4. Wipe the body of the rice cooker clean with a damp cloth.
- Do not use harsh abrasive cleaners.
 - This appliance is NOT dishwasher safe. Inner pot is NOT dishwasher safe.

COOKING GUIDES

Rice/Water Measurement Chart:

UNCOOKED RICE	WATER WITH MEASURING CUP	WATERLINE INSIDE POT	APPROX COOKED RICE YIELD
1 Cup	1-1/2 Cups	line 1	2 Cups
2 Cups	2-1/2 Cups	line 2	4 Cups
3 Cups	3-1/2 Cups	line 3	6 Cups
4 Cups	4-1/2 Cups	line 4	8 Cups
5 Cups	5-1/2 Cups	line 5	10 Cups
6 Cups	6-1/2 Cups	line 6	12 Cups
7 Cups	7-1/2 Cups	line 7	14 Cups
8 Cups	8-1/2 Cups	line 8	16 Cups
9 Cups	9-1/2 Cups	line 9	18 Cups
10 Cups	10-1/2 Cups	line 10	20 Cups

NOTE

- When cooking brown or wild rice, add an additional 3/4 cup water.
- The measuring cup included is not an exact cup. Chart refers to cups of rice/water based on the measuring cup provided.

HELPFUL HINTS:

1. Rinse rice to remove excess bran and starch. This will help reduce browning and sticking to the bottom of the pot, but it may also reduce nutrients in rice.
2. If you have experienced any sticking due to the type of rice you are using, try adding a light coating of vegetable oil or non-stick spray to the bottom of the inner pot before adding rice.
3. This is only a general measuring guide. As there are many different kinds of rice available (see *About Rice* on page 9), rice/water measurement may vary slightly.

COOKING GUIDES

Steaming Chart:

VEGETABLE	AMOUNT OF WATER	STEAMING TIME
Asparagus	1/2 Cup	10 Minutes
Broccoli	1/4 Cup	5 Minutes
Cabbage	1 Cup	15 Minutes
Carrots	1 Cup	15 Minutes
Cauliflower	1 Cup	15 Minutes
Corn	1 Cup	15 Minutes
Eggplant	1-1/4 Cup	20 Minutes
Green Beans	1 Cup	15 Minutes
Peas	1/2 Cup	10 Minutes
Spinach	1/2 Cup	10 Minutes
Squash	1/2 Cup	10 Minutes
Zucchini	1/2 Cup	10 Minutes

HELPFUL HINTS:

1. Since most vegetables only absorb a small amount of water, there is no need to increase the amount of water with a larger serving of vegetables.
2. Always keep the lid closed during the entire steaming process. Opening the lid causes a loss of heat and steam, resulting in a slower cooking time. If you find it necessary to open the lid, you may want to add a small amount of water to help restore the cooking time.
3. Altitude, humidity and outside temperature will affect cooking times.
4. The steaming chart is for reference only. Actual cooking time may vary.

ABOUT RICE

Rice is a valuable source of low fat, complex carbohydrates and is abundant in thiamin, niacin and iron. It is an essential ingredient for a healthy diet.

There are many different varieties of rice available in the market. Your Aroma Rice Cooker can cook any type perfectly every time. Following are the commonly available varieties of rice and their characteristics:

Long Grain Rice

Typically this rice is not starchy and has loose, individual grains after cooking. The "California" rice is soft; "Carolina" is a little firmer, and "Jasmine" is the firmest of the long grain variety and is flavorful and aromatic.

Short Grain Rice

Short grain is characteristically soft, sticky and chewy. This is the rice used to make sushi. "California Rice" is soft; "Sweet Rice", often called "pearl" rice for its round shape, is extra sticky and is excellent for making rice pudding.

Brown Rice

Brown rice is often considered the most healthy variety. It has bran layers on the rice grains and contains more B-complex vitamins, iron, calcium, and fiber than polished (white) rice. The most popular brown rice is long grain and has a chewy texture.

Wild Rice

Wild Rice comes in many delicious varieties and mixes. Often it is mixed with long grain rice for its firmer texture and rich brown to black color. Wild rice makes wonderful stuffing for poultry when cooked with broth and mixed with your favorite dried fruits.

LIMITED WARRANTY

Aroma Housewares Company warrants this product free from defects in material and workmanship for one year from provable date of purchase in continental United States.

Within this warranty period, Aroma Housewares Company will repair or replace, at its option, defective parts at no charge, provided the product is returned, freight prepaid with proof of purchase and U.S. \$8.00 for shipping and handling charges payable to Aroma Housewares Company. Before returning an item, please call the toll free number below for return authorization number. Allow 2-4 weeks for return shipping.

This warranty does not cover improper installation, misuse, abuse or neglect on the part of the owner. Warranty is also invalid in any case that the product is taken apart or serviced by an unauthorized service station.

This warranty gives you specific legal rights and which may vary from state to state and does not cover areas outside the United States.

AROMA HOUSEWARES COMPANY
6469 Flanders Drive
San Diego, California 92121
1-800-276-6286
M-F, 8:30 AM - 5:00 PM, Pacific Time
Website: www.aromaco.com