

# AROMA®

10-Cup Digital Rice  
Cooker & Food Steamer

Instruction Manual



Congratulations on your purchase of the Aroma® Sensor Logic 10-Cup Digital Rice Cooker. In no time at all, you'll be making fantastic, restaurant-quality rice at the touch of a button! Whether long, medium or short grain, this machine is specially calibrated to cook all varieties of rice, including tough-to-cook brown rice, to fluffy perfection.

In addition to rice, your new Aroma® Rice Cooker is ideal for healthy, one-pot meals for the whole family. The convenient steam tray inserts directly over the rice, allowing you to cook moist, fresh meats and vegetables at the same time, in the same pot. Steaming foods locks in their natural flavor and nutrients (which are often lost with other methods of cooking) without added oil or fat, for meals that are as nutritious and low-calorie as they are easy.

But it doesn't end there. Your new rice cooker is also great for soups, stews, stocks, gumbos, jambalaya, breakfast frittatas, dips and even desserts! Several delicious recipes are included at the back of this manual.

This manual contains instructions for using your rice cooker and its convenient pre-programmed digital settings, as well as all of the accessories included. Also included are helpful measurement charts for cooking rice and steaming. For more information on your Sensor Logic rice cooker, or for product service, recipes and other home appliance solutions, please visit us online at [www.AromaCo.com](http://www.AromaCo.com).

Published By:

Aroma Housewares Co.  
6469 Flanders Drive  
San Diego, CA 92121  
U.S.A.  
1-800-276-6286  
[www.aromaco.com](http://www.aromaco.com)

© 2008 Aroma Housewares Company All rights reserved.

# IMPORTANT SAFEGUARDS

*Basic safety precautions should always be followed when using electrical appliances, including the following:*

1. Important: Read all instructions carefully before first use.
2. Do not touch hot surfaces. Use the handles or knobs.
3. Use only on a level, dry and heat-resistant surface.
4. To protect against electrical shock, do not immerse cord, plug or the appliance in water or any other liquid.
5. Close supervision is necessary when the appliance is used by or near children.
6. Unplug from outlet when not in use and before cleaning. Allow unit to cool before putting on or taking off parts and before cleaning the appliance.
7. Do not operate any appliance with a damaged cord or plug or after the appliance malfunctions or has been damaged in any manner. Return the appliance to the nearest authorized service facility for examination, repair or adjustment.
8. The use of accessory attachments not recommended by the appliance manufacturer may result in fire, electrical shock or injury.
9. Do not use outdoors.
10. Do not let cord touch hot surfaces or hang over the edge of a counter or table.
11. Do not place on or near a hot burner or in a heated oven.
12. Do not use the appliance for other than its intended use.
13. Extreme caution must be used when moving the appliance containing hot water or other liquids.
14. Do not touch, cover or obstruct the steam vent on the top of the rice cooker as it is extremely hot and may cause scalding.
15. Use only with a 120V AC power outlet.
16. Always unplug from the base of the wall outlet. Never pull on the cord.
17. The rice cooker should be operated on a separate electrical circuit from other operating appliances. If the electrical circuit is overloaded with other appliances, the appliance may not operate properly.
18. Always make sure the outside of the inner cooking pot is dry prior to use. If the cooking pot is returned to cooker when wet, it may damage or cause the product to malfunction.
19. Use extreme caution when opening the lid during or after cooking. Hot steam will escape and may cause burns.
20. Rice should not be left in the rice pot with the keep warm function on for more than 12 hours.
21. To prevent damage or deformation, do not use the inner pot on a stovetop or burner.
22. To disconnect, turn any control to "OFF", then remove plug from wall outlet.
23. To reduce the risk of electrical shock, cook only in the removable container provided.

## SAVE THESE INSTRUCTIONS

## SHORT CORD INSTRUCTIONS

1. A short power-supply cord is provided to reduce the risks resulting from becoming entangled in or tripping over a longer cord.
2. Longer extension cords are available and may be used if care is exercised in their use.
3. If a longer extension cord is used:
  - a. The marked electrical rating of the extension cord should be at least as great as the electrical rating of the appliance.
  - b. The longer cord should be arranged so that it will not drape over the counter top or tabletop where it can be pulled by children or tripped over unintentionally.

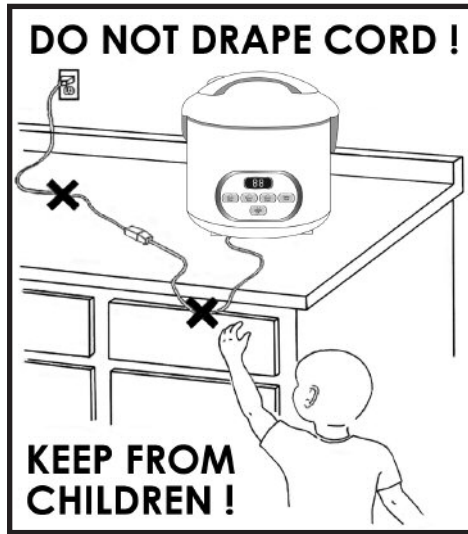

## POLARIZED PLUG

This appliance has a polarized plug (one blade is wider than the other); follow the instructions below:

To reduce the risk of electric shock, this plug is intended to fit into a polarized outlet only one way. If the plug does not fit fully into the outlet, reverse the plug. If it still does not fit, contact a qualified electrician. Do not attempt to modify the plug in any way.

If the supply cord is damaged, it must be replaced by the manufacturer, its service agent or a similarly qualified person in order to avoid a hazard.

**This appliance is for household use only.**

# PARTS IDENTIFICATION

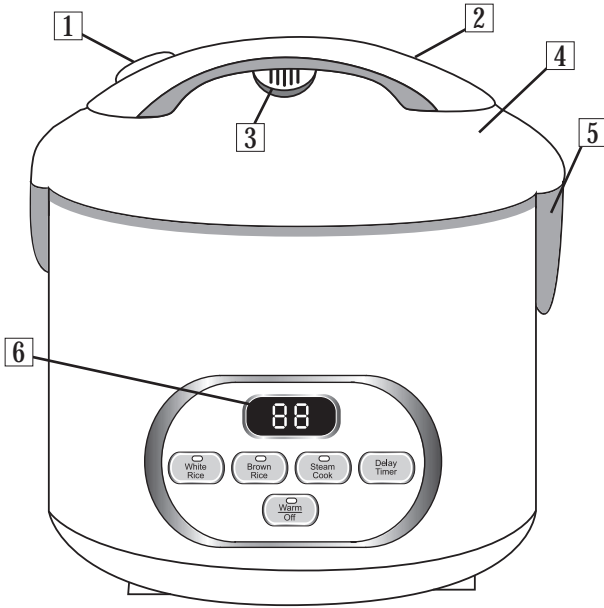

1. Lid Release Button
2. Handle
3. Steam Vent
4. Lid
5. Condensation Collector
6. Digital Display
7. Inner Pot

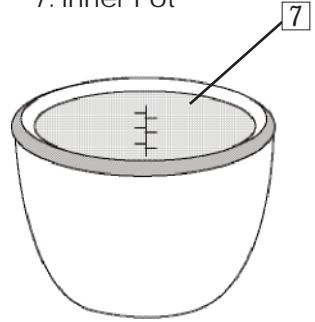

## Control Panel

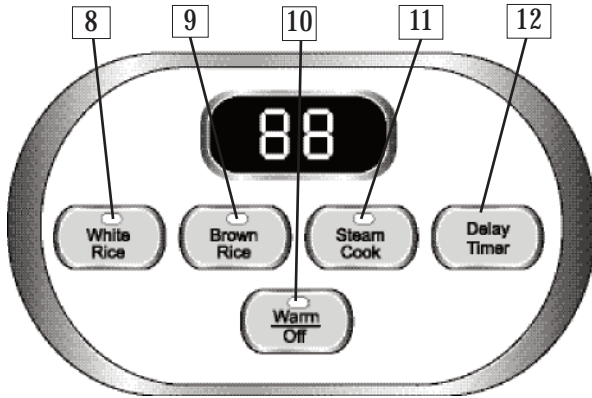

8. White Rice Button/  
Indicator Light
9. Brown Rice Button/  
Indicator Light
10. Warm/Off Button/  
Indicator Light
11. Steam/Cook  
Button/  
Indicator Light
12. Delay Timer Button

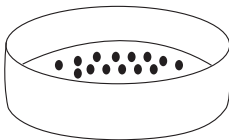

Steam Tray



Measuring Cup



Rice Paddle

# USING YOUR RICE COOKER

## Before First Use:

1. Read all instructions and important safeguards.
  2. Remove all packaging materials and make sure items are received in good condition.
  3. Tear up all plastic bags as they can pose a risk to children.
  4. Wash lid, steam vent and accessories in warm, soapy water. Rinse and dry thoroughly.
  5. Remove inner pot from rice cooker and clean with warm, soapy water. Rinse and dry thoroughly before returning to cooker.
  6. Wipe body clean with a damp cloth.
- Do not use abrasive cleaners or scouring pads.
  - Do not immerse the rice cooker base, cord or plug in water at any time.

## To Cook Rice:

1. Using the measuring cup provided, measure out the desired amount of rice. One full, level cup of uncooked rice will yield 2 cups of cooked rice. The measuring cup provided adheres to rice industry standards (180mL) and is not equal to one U.S. cup (240 mL).
2. Rinse rice in a separate container until the water becomes relatively clear; drain.
3. Place rinsed rice in the inner pot.
4. Using the measuring cup provided or the water measurement lines located inside the inner pot, add the appropriate amount of water. If you are making brown rice, follow the rice/water measuring guide for brown rice located on page 9 of this manual. Do not use the water measurement lines inside the inner pot for brown rice, they are intended for white rice only.
5. For softer rice, allow rice to soak for 10-20 minutes prior to cooking.
6. Making sure that the exterior of the inner pot is clean, dry and free of debris; set the inner pot in the rice cooker. Snap the lid closed and plug the power cord into a wall outlet.  
*\* To avoid loss of steam and longer cooking times, do not open the lid at any point during the cooking process.*
7. To begin cooking, press the "WHITE RICE" or "BROWN RICE" button, depending on the type of rice to be cooked. The cooking mode indicator light will illuminate. Once cooking is complete, the rice cooker will automatically switch to keep warm mode.
8. After cooking, open the lid and use the rice paddle to stir the rice. This will release excess moisture and give the rice a fluffier texture. Then, close the lid and allow the unit to remain on warm mode for 5-10 minutes. This will ensure optimal rice texture and moisture level.
9. Press the "WARM/OFF" button to turn off the rice cooker. If the "WARM/OFF" button is not pressed, the rice cooker will remain in keep warm mode. It is not recommended to leave rice on keep warm mode for more than 12 hours.

# USING YOUR RICE COOKER

\* It is important that the outside surface of the inner pot is completely clean and dry before it is placed into the rice cooker. Water, food or other substances on the pot will come into contact with the heating element and may cause damage to the product.

## To Use Delay Timer:

1. Press the "DELAY TIMER" button (in 1-hour increments) until it displays the number of hours in which you would like your rice to be finished cooking.
2. Press "WHITE RICE" or "BROWN RICE" after you have made your choice.
3. Press the "WARM/OFF" button to cancel your choice and reset.
4. When cooking has completed, the rice cooker will automatically switch to keep warm mode.
5. The rice cooker will remain on keep warm mode until it is unplugged. Be sure to unplug the cord from the wall outlet when not in use.

### NOTE

The digital display on this unit is for the delay timer function only. When using cooking or warming mode, the display will show two red lines (See illustration below).

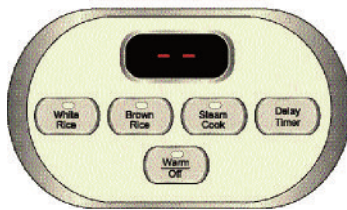

## To Steam Food:

1. Add the desired amount of water to the inner pot. A convenient steaming guide has been included on page 11 for vegetables and page 12 for meat.
2. Place steam tray inside rice cooker.
3. Place food on steam tray and close the lid.
4. Press the "STEAM COOK" button.
5. When steaming is complete, the rice cooker will automatically switch to keep warm mode.
6. Remove food immediately after cooking process has completed. Leaving it in the rice cooker may cause food to over cook.
7. The rice cooker will remain on keep warm mode until it is unplugged. Be sure to unplug the cord from the wall outlet when not in use.

SEE PAGE 6 FOR INSTRUCTIONS ON COOKING RICE  
AND STEAMING SIMULTANEOUSLY.

# USING YOUR RICE COOKER

## CAUTION:

- Open the lid only when necessary.
- If cooking pot is returned to cooker when wet it will damage this product, causing it to malfunction.

## To Steam Food And Cook Rice Simultaneously:

One of the most convenient features of this rice cooker is the ability to both cook rice and steam food simultaneously, ideal for creating delicious all-in-one meals.

1. Place the desired amount of rice and appropriate amount of water into the inner pot. See *"To Cook Rice"* on page 4 for details. Do not attempt to cook more than 8 cups (uncooked) of rice if trying to use the steam tray simultaneously. The steam tray will not fit.
2. Place the inner pot into the unit and begin to cook the rice.
3. Refer to the steaming guides for vegetables (page 11) or meat (page 12) for hints and approximate steaming times. It is best to insert the food to be steamed toward the end of the rice cooking cycle so that your meal is fresh and warm all at once. See the cooking time chart included on Page 10 for approximate rice cooking times.
4. Place your choice of vegetables or meat into the steam tray. Open the lid, using caution as steam escaping will be extremely hot, and place steam tray into the rice cooker.
5. Close the lid and allow the cooker to resume cooking.
6. Once food has been steamed for the appropriate time open the lid. Use caution when opening lid as steam escaping will be extremely hot. Remove the steam tray and check food to be sure it has been thoroughly cooked. Exercise caution when removing the steam tray as well, as it will be hot.
7. If the rice has not finished cooking, close the lid of the rice cooker and allow rice to continue to cook until done. Once the rice is finished, the rice cooker will automatically switch to keep warm mode.
8. The rice cooker will remain on keep warm mode until it is unplugged. Be sure to unplug the cord from the wall outlet when not in use.

## NOTE

It is possible to steam at any point during the rice cooking cycle. However, it is recommended that you steam during the end of the cycle so that steamed food does not grow cold or become soggy before the rice is ready.

# USING YOUR RICE COOKER

## To Cook Soups and Stews:

---

1. Add ingredients to inner pot.
2. Making sure that the exterior of the inner pot is clean, dry and free of debris; set the inner pot into the rice cooker. Close the lid and plug the power cord into a wall outlet.
3. Press the "STEAM/COOK" button. The "STEAM/COOK" indicator light will illuminate.
4. Allow soup to cook until ready, stirring often.
5. When soup is finished cooking, press the "WARM/OFF" button. The cooker will then switch to keep warm mode.
6. The rice cooker will remain in keep warm mode until it is unplugged. Be sure to unplug the unit from the wall outlet when it is not in use.

### HELPFUL HINTS

1. Rinse rice before placing it into the inner pot to remove excess bran and starch. This will help reduce browning and sticking to the bottom of the pot.
2. If you have experienced any sticking with the type of rice you are using, try adding a light coating of vegetable oil or non-stick spray to the bottom of the inner pot before adding rice.
3. As there are many different kinds of rice available (see *About Rice* on page 14), rice/water measurements may vary slightly.
4. For softer rice, allow it to soak for 10-20 minutes prior to cooking.

# HOW TO CLEAN

*Always unplug unit and allow to cool completely before cleaning.*

1. Remove the inner cooking pot. Wash it in warm, soapy water using a sponge or dishcloth.
2. Rinse and dry thoroughly.
3. Repeat process with steam tray and other provided accessories.
4. Wipe the underside of the lid with a warm, damp cloth. Dry with a soft cloth.
5. Wipe the body of the rice cooker and the underside of the lid clean with a damp cloth.
6. To clean the steam vent (clean after each use):
  - Pull out the steam vent as shown in Diagram 1.
  - Empty and wash the steam vent in warm, soapy water. Rinse thoroughly.
  - Dry the steam vent with a soft cloth.
  - Reinsert the steam vent for next use.

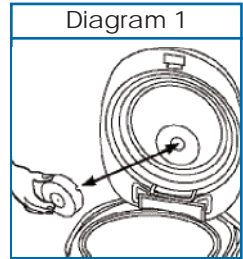

- Do not use harsh abrasive cleaners, scouring pads or products that are not considered safe to use on non-stick coatings.
- This appliance is NOT dishwasher safe. Inner pot and accessories are NOT dishwasher safe.
- Always make sure the outside of the inner pot is dry prior to use. If the inner cooking pot is returned to the rice cooker when wet, it may damage this product, causing it to malfunction.

# COOKING GUIDE

## White Rice/Water Measurement Chart:

UNCOOKED RICE	<u>WHITE RICE</u> WATER WITH MEASURING CUP	<u>WHITE RICE</u> WATERLINE INSIDE POT	APPROX COOKED RICE YIELD
2 Cups	2-1/2 Cups	Line 2	4 Cups
3 Cups	3-1/2 Cups	Line 3	6 Cups
4 Cups	4-1/2 Cups	Line 4	8 Cups
5 Cups	5-1/2 Cups	Line 5	10 Cups
6 Cups	6-1/2 Cups	Line 6	12 Cups
7 Cups	7-1/2 Cups	Line 7	14 Cups
8 Cups	8-1/2 Cups	Line 8	16 Cups
9 Cups	9-1/2 Cups	Line 9	18 Cups
10 Cups	10-1/2 Cups	Line 10	20 Cups

## Brown Rice/Water Measurement Chart:

UNCOOKED RICE	<u>BROWN RICE</u> WATER WITH MEASURING CUP	APPROX COOKED RICE YIELD
2 Cups	3 Cups	4 Cups
3 Cups	4-1/4 Cups	6 Cups
4 Cups	5-1/2 Cups	8 Cups
5 Cups	6-3/4 Cups	10 Cups
6 Cups	8 Cups	12 Cups
7 Cups	9-1/4 Cups	14 Cups
8 Cups	10-1/2 Cups	16 Cups

\* Due to the extra water needed to cook brown rice, the maximum amount of brown rice that may be cooked at one time is 8 cups.

### SPECIAL INSTRUCTIONS

- Brown rice, wild rice and rice mixes vary in their make-up. Some variations may require longer cooking times and/or additional water in order to achieve optimum results. Refer to the individual package instructions for cooking suggestions.
- The measuring cup included adheres to rice industry standards (180mL) and is not equal to one U.S. cup (240mL). The chart above refers to cups of rice/water according to the measuring cup provided.
- Do not place more than 10 cups of uncooked rice (8 cups if brown rice) into this appliance at one time. The maximum capacity of this unit is 10 cups raw rice (8 cups if brown rice) which yields 20 cups of cooked rice (16 cups brown rice).

# COOKING GUIDE

## HELPFUL HINTS

1. Rinse rice before placing into the inner pot to remove excess bran and starch. This will help reduce browning and sticking to the bottom of the pot.
2. If you have experienced any sticking with the type of rice you are using, try adding a light coating of vegetable oil or non-stick spray to the bottom of the inner pot before adding rice.
3. The chart on page 9 is only a general measuring guide. As there are many different kinds of rice available (see *About Rice* on page 14), rice/water measurements may vary slightly.

## Cooking Time Chart:

WHITE RICE UNCOOKED CUPS	COOKING TIME	BROWN RICE UNCOOKED CUPS	COOKING TIME
2 Cups	30-35 Min	2 Cups	100-105 Min
3 Cups	32-37 Min	3 Cups	102-107 Min
4 Cups	34-39 Min	4 Cups	110-115 Min
5 Cups	38-43 Min	5 Cups	114-119 Min
6 Cups	40-45 Min	6 Cups	116-121Min
7 Cups	41-46 Min	7 Cups	118-123 Min
8 Cups	43-48 Min	8 Cups	120-125 Min
9 Cups	44-49 Min	9 Cups	N/A
10 Cups	46-51 Min	10 Cups	N/A

Cooking times are approximate. This table is for reference only. Possible variations in cooking times may be caused by one or more of the following factors:

- Variations in the type of rice being cooked.
- Variations in the amount of rice and/or water in the inner pot.
- If you are making a second batch of rice shortly after the first batch, cooking times may be reduced because the heating element will already be warm.
- Opening the lid during the cooking cycle causes a loss of heat and steam. Cooking time may be prolonged if the lid is opened before the rice is finished.

# COOKING GUIDE

## VEGETABLE STEAMING CHART:

VEGETABLE	AMOUNT OF WATER	STEAMING TIME
Asparagus	1/2 Cup	10 Minutes
Broccoli	1/4 Cup	5 Minutes
Cabbage	1 Cup	15 Minutes
Carrots	1 Cup	15 Minutes
Cauliflower	1 Cup	15 Minutes
Corn	1 Cup	15 Minutes
Eggplant	1-1/4 Cup	20 Minutes
Green Beans	1 Cup	15 Minutes
Peas	1/2 Cup	10 Minutes
Spinach	1/2 Cup	10 Minutes
Squash	1/2 Cup	10 Minutes
Zucchini	1/2 Cup	10 Minutes

### HELPFUL HINTS

1. Since most vegetables only absorb a small amount of water, there is no need to increase the amount of water with a larger serving of vegetables.
2. When steaming and cooking rice simultaneously, follow the instructions on page 6. Place the steam tray over the rice as it cooks for the amount of time needed, checking the food every so often for doneness. Do not cook more than 8 cups (6 cups if brown rice) uncooked rice while steaming, or the steam tray will not fit into the rice cooker.
3. When possible, keep the lid closed during the entire steaming process. Opening the lid causes a loss of heat and steam, resulting in a slower cooking time. If you find it necessary to open the lid, you may want to add a small amount of water to help restore the cooking time.
4. Altitude, humidity and outside temperature will affect cooking times.
5. This steaming chart is for reference only. Actual cooking time may vary.

# COOKING GUIDE

## MEAT STEAMING CHART:

Meat	Amount of Water	Steaming Time	Safe Internal Temperature
Fish	2 Cups	15 Min.	140°
Chicken	2-1/2 Cups	20 Min.	165°
Pork	2-1/2 Cups	20 Min.	160°
Beef	2-1/2 Cups	Medium = 15 Min. Medium-Well = 20 Min. Well = 23 Min.	160°

### NOTE

1. Steaming times may vary depending on the cut of meat being used.
2. To ensure meat tastes its best, and to prevent possible illness, check that meat is completely cooked prior to serving. If it is not, simply place more water in the inner pot and repeat the cooking process until the meat is adequately cooked.

# TROUBLESHOOTING

Because rice varieties may vary in their make-up, results may differ. Below are some troubleshooting tips to help you achieve the desired consistency.

PROBLEM	SOLUTION
Rice is too dry/hard after cooking.	If your rice is dry or hard/chewy when the rice cooker switches to keep warm mode, additional water and cooking time will soften the rice. Depending on how dry your rice is, add ½ to 1 cup of water and stir through. Close the lid and press the “STEAM/COOK” button. When rice cooker switches to warm mode, open the lid and stir the rice to check the consistency. Repeat as necessary until rice is soft and moist.
Rice is too moist/soggy after cooking.	If your rice is still too wet or soggy when the rice cooker switches to keep warm mode, use the rice paddle to stir the rice. This will redistribute the bottom (moistest) part of the rice as well as release excess moisture. Close the lid and allow to remain on keep warm mode for 10-30 minutes as needed, opening the lid and stirring periodically to release excess moisture.

## ABOUT RICE

Rice is a valuable source of low fat, complex carbohydrates and is abundant in thiamin, niacin and iron. It is an essential ingredient for a healthy diet.

There are many different varieties of rice available in the market. Your Aroma® Rice Cooker can cook any type perfectly every time. Following are the commonly available varieties of rice and their characteristics:

### Long Grain Rice

Typically this rice is not starchy and has loose, individual grains after cooking. "Carolina" is firm, and "Jasmine" is the firmest of the long grain variety and is flavorful and aromatic.

### Short Grain Rice

Short grain is characteristically soft, sticky and chewy. This is the rice used to make sushi. "California Rice" is soft; "Sweet Rice", often called "pearl" rice for its round shape, is extra sticky and is excellent for making rice pudding.

### Brown Rice

Brown rice is often considered the most healthy variety. It has bran layers on the rice grains and contains more B-complex vitamins, iron, calcium, and fiber than polished (white) rice. The most popular brown rice is long grain and has a chewy texture.

### Wild Rice

Wild Rice comes in many delicious varieties and mixes. Often it is mixed with long grain rice for its firmer texture and rich brown to black color. Wild rice makes wonderful stuffing for poultry when cooked with broth and mixed with your favorite dried fruits.

## HELPFUL HINTS

- Spraying the inner pot with a light coating of nonstick cooking spray is a great way to make cleanup easier without adding flavor or calories to your meal.
- When a recipe calls for salt, use kosher salt. It has no impurities or additives and dissolves easily. You will need to use about half again more kosher salt than you would table salt.
- If the rice cooker shuts off before the food is totally cooked, add more water and start the cooker again.
- Stocks and broths can be used in place of water to add flavor and improve texture when cooking rice. Stocks and broths can be found in your local supermarket. Another option is to use bouillon cubes (they come in a wide variety of flavors). One cube and one cup of water usually makes one cup of stock.

### Safety Considerations:

- 1) Rice cookers cook at very high temperatures and will produce large amounts of steam. Use extreme caution when opening rice cooker during and after the cooking cycle. When lifting the hinged cover, keep hands and face away from the rice cooker to avoid the steam.
- 2) If a recipe calls for the sauteing of butter or oil, use extreme caution, as you would when cooking with other high-temperature devices like a stove or oven. The inner pot will be hot, so use a long-handled plastic or wooden spoon for stirring. **DO NOT USE** the short-handled rice paddle for this type of cooking.
- 3) It is important to remember that the cooking cycle of the rice cooker is controlled by the temperature of the inner pot. When liquid boils off, the temperature will rise, causing the rice cooker to automatically shift into the low temperature 'keep warm' mode. This is fine for making rice dishes but if a recipe calls for steaming or making soups, where copious quantities of liquid are used, the rice cooker will not shut off until all liquid is boiled away. Follow the recipes carefully and do not leave the rice cooker unattended as it will continue to cook at high temperatures when making soups, stews and steaming. Monitor the cooking process and **MANUALLY TURN OFF** the rice cooker when the time that the recipe stipulates has elapsed.

## RECIPES

### San Antonio Rice

---

1 cup	uncooked long-grain rice
1 jar (12oz.)	fresh salsa, mild or hot
1 tbsp.	vegetable oil
1 cup	fresh or canned corn kernels
1/2 tsp.	ground cumin
1/2 tsp.	salt
	fresh ground black pepper to taste
1-1/4 cups	water
	minced fresh cilantro for garnish (optional)

Add all ingredients except cilantro to the inner pot, stir, close the lid, and press the "WHITE RICE" button. When rice cooker switches to warm mode, open the cooker, quickly stir and re-cover. Allow to stand for 8-10 minutes before serving. Spoon onto a serving dish, garnish with fresh cilantro and serve. Makes a flavorful supper or side dish for grilled chicken or fish. Serves 3-4.

### Thai-Style Rice

---

1 cup	uncooked long-grain Jasmine rice
2 cups	canned coconut milk
1/4 tsp.	ground cardamom
1/2 tsp.	ground coriander
1/4 tsp.	salt
	ribbons of fresh basil leaves or cilantro leaves for garnish (optional)

Add all ingredients to the inner pot except basil or cilantro. Close the lid, press the "WHITE RICE" button and cook until the rice cooker switches to warm mode, about 20 minutes. Allow to stand 10 minutes before serving. Goes well with spicy foods. Serves 3-4.

## Orange Rice Pilaf

2 tbsp.	unsalted butter
1/4 cup	onion, finely chopped or 1 tbsp. dried onion flakes
-	grated zest of 1 orange
-	juice of 2 oranges plus enough chicken broth to make 1-3/4 cups liquid
1 cup	long-grain rice
1/2 tsp.	kosher salt
1/4 cup	slivered toasted almonds for garnish

Add all ingredients to inner pot except toasted almonds. Close lid, press "STEAM/COOK" button and cook until liquid evaporates, about 20 minutes. Allow to stand for 10 minutes. Spoon into a serving bowl, top with toasted almonds and serve immediately. Goes well with almost any fish, chicken or pork dish. Serves 3-4.

## Lemon Dill Rice

1 cup	long-grain Jasmine rice
1-3/4 cups	water
1/2 tsp.	salt
-	grated zest of 1 lemon
1 tbsp.	lemon juice
1/2 tsp.	dried dill weed
1 tsp.	dried parsley, or 1 tbsp. minced fresh flat-leaf parsley
2 tbsp.	butter, cut into 4 pieces
-	kosher salt and freshly ground black pepper to taste

Add all ingredients to the inner pot and stir to combine. Place inner pot in the rice cooker and close the lid. Press the "WHITE RICE" button and cook until rice cooker switches to warm mode. Allow rice to stand, covered, for 10 minutes. Adjust seasoning as desired. Pour into a serving bowl and serve immediately. Makes a delicious accompaniment for fish and chicken dishes. Serves 4.

\* Add shrimp or scallops and frozen peas during the last five minutes of cooking to make a main dish.

# Cranberry Mango Wild Rice Salad

---

1-1/2 cups uncooked wild and brown rice mix  
3 cups water  
1/3 cup dried cranberries  
1/4 cup red bell pepper, chopped  
1/3 cup fresh mango, chopped  
3 tbsp. walnuts, chopped

## Dressing:

1/3 cup vegetable oil  
1/4 cup rice vinegar  
2 tsp. sugar  
1 tsp. dried basil leaves  
1 tsp. dried parsley  
1/4 tsp. salt  
freshly ground pepper to taste

Place the rice and water in the inner pot. Press the "BROWN RICE" button. Cook until the rice is done, about 1 hour, 45 minutes. Remove the rice to a large bowl and cool. When the rice has cooled, add the cranberries, red bell pepper, mango and walnuts. Fold in gently.

In a small bowl, whisk together the dressing ingredients and drizzle over the salad. Mix gently to combine, cover and chill for up to 4 hours before serving. Serves 4.

## Savory Lentils

---

2 tbsp.	extra virgin olive oil
1/2 tsp.	curry powder
1 tsp.	ground cumin
1 cup	brown or green lentils, picked over and washed
2-2/3 cups	water
1 can (14 oz)	tomato pieces with juice
2 tbsp.	dried minced onion
1 tbsp.	dried vegetable flakes
2 tbsp.	dried parsley
-	kosher salt and freshly ground black pepper to taste

Add all ingredients to inner pot and stir. Place inner pot in the rice cooker, close the lid, and press the "STEAM/COOK" button. Allow to cook until the rice cooker switches to warm mode. Midway through cooking, carefully open rice cooker, stir ingredients with a long-handled wooden spoon and re-cover. Keep face and hands away from the inner pot when opening the lid to avoid steam burns. Inner pot will be hot, so use caution and be sure that your stirring utensil has a long handle to avoid burning your hands on the inner pot. When rice cooker switches to keep-warm mode, carefully open the lid, stir again and re-cover. Allow to stand for 10 minutes before serving. Serves 4.

## Green Chile and Chicken Rice

---

1-1/2 cups	medium-grain rice, such as Calrose
3 cups	low sodium chicken broth
2 tbsp.	dried minced onion
1/2 tsp.	kosher salt
1 can (10 oz)	chicken breast chunks with liquid
1 can (4 oz)	diced green chiles with liquid
-	salt to taste

Place all ingredients in the inner pot and stir. Place inner pot into the rice cooker, cover and press the "STEAM/COOK" button. Allow to cook until rice cooker switches to warm mode. Add salt to taste. Stir and serve immediately as a main course. Serves 4.

## Shrimp with Saffron Rice

---

1 cup	Jasmine or other long-grain rice
1 cup	low sodium chicken broth
1 bottle (8 oz)	clam juice, or 1 cup water
2 tbsp.	unsalted butter
1 tbsp.	dried minced onion
-	zest of 1 lemon
2 tbsp.	lemon juice
1	generous pinch of saffron
5-6 drops	Tabasco sauce, or to taste
-	kosher salt and freshly ground black pepper to taste
8 oz.	large shrimp, peeled, de-veined, tails left on
-	fresh or dried minced chives for garnish

Place all ingredients, except shrimp and chives, in the inner pot and place in the rice cooker. Press the "STEAM/COOK" button. After liquid begins to boil, cook the rice for 10 minutes. Carefully open the rice cooker, keeping hands and face away to avoid steam burns and add shrimp on top of rice. Cover and continue to cook until the rice cooker switches to warm mode. Serve immediately and garnish with chives. Do not allow to stand after rice cooker switches to warm mode because shrimp will be overcooked. Serves 2-3.

## Basic Steamed Chicken Breasts

---

2	boneless, skinless chicken breasts
-	kosher salt and freshly ground black pepper to taste

Season chicken breasts with salt and pepper. Place chicken breasts in the steam tray. You may also place chicken breasts on a plate that is just large enough to fit into the steam tray with about 1/2-inch clearance for steam circulation. If using a plate, spray plate with nonstick cooking spray, place seasoned chicken on the plate and cover with plastic wrap. Add 1 cup water to inner pot and place in the rice cooker. Place steam tray with chicken breasts into the inner pot. Cover and press the "STEAM/COOK" button. Steam for about 10 minutes, or until chicken is firm to the touch and no pink is left in the center. Using oven mitts, carefully remove steam tray from rice cooker and serve chicken immediately. Serves 2.

## Soy Sauce Marinated Chicken Breasts

2	boneless, skinless chicken breasts or turkey breast cutlets, about 3/4-inch thick
2 tbsp.	soy sauce
1 tbsp.	sugar
1 tsp.	toasted sesame oil
1	small clove garlic, minced
1/2 tsp.	grated fresh ginger
1	green onion, white part with 1 inch of green, cut into slivers

Combine soy sauce, sugar, sesame oil, garlic, and ginger with chicken breasts and marinate for 10-15 minutes. Choose a plate that is just large enough to fit into the steam tray with about 1/2-inch clearance for steam circulation. Place chicken breasts and marinade on plate sprayed with nonstick cooking spray, top with slivered onion, and cover plate with plastic wrap. Add 1 cup of water to inner pot. Place steam tray into the inner pot and place inner pot into the rice cooker. Close lid and press the "STEAM/COOK" button. Steam for about 10 minutes, or until chicken is firm to the touch and no pink is left in the center. Using oven mitts, carefully remove steam tray from the rice cooker and serve chicken immediately. Serves 2.

## Chicken Breasts Dijon

2	boneless, skinless chicken breasts
1 tbsp.	Dijon-style mustard
1 tbsp.	plain yogurt
1/2 tsp.	sambal oelek (a mixture of chiles, brown sugar, and salt), optional
-	kosher salt and freshly ground black pepper to taste
1 tsp.	dried chives

Place chicken breasts on a small plate sprayed with nonstick cooking spray. Mix together mustard, yogurt, sambal oelek, salt and pepper. Spread over chicken breast and sprinkle with chives. Cover chicken and plate with plastic wrap and place plate in steam tray. Add 1 cup of water to inner pot. Place steam tray in inner pot and place inner pot in the rice cooker. Cover and press the "STEAM/COOK" button. Steam for about 10 minutes, or until chicken is firm to the touch and no pink is left in the center. Using oven mitts, carefully remove steam tray from rice cooker and serve chicken immediately. Serves 2.

## Steamed Turkey Tenderloins

- 2 turkey tenderloins, about 10-11 oz. each
- kosher salt and ground black pepper to taste

Add 3 cups of water to inner pot, place inner pot in rice cooker, cover and press "STEAM/COOK" button to let water come to a boil. Season tenderloins with salt and pepper. Place tenderloins in the steam tray. You may also choose a plate that is just large enough to fit into the steam tray with about 1/2-inch clearance for steam circulation. If using a plate, spray with nonstick cooking spray before placing tenderloins on the plate and cover with plastic wrap before placing in the steam tray. When water has come to a boil in the rice cooker, carefully open lid, keeping hands and face away to avoid steam burns. Using oven mitts (inner pot will be hot), carefully place the steam tray into the rice cooker, cover, and steam for about 25 minutes. Check after 20 minutes with an instant meat thermometer. Turkey should reach about 160°F and not be pink in the center. Using oven mitts, remove steam tray from rice cooker. A general rule is to stand for about 15 minutes per 1-inch thickness. Refrigerate if not serving immediately. Serves 4.

## Basic Steamed New Potatoes

- 1-2 lbs. small new potatoes (about 1-2 inches in diameter), scrubbed, unpeeled

Add potatoes in one layer to steam tray. Add 3 cups water to the inner pot. Place inner pot in the rice cooker and place steam tray into the inner pot. Close lid and press the "STEAM/COOK" button. Allow to cook until potatoes are tender, about 20 minutes after water begins to boil. Test potatoes: carefully open the lid, keeping hands and face away to avoid steam burns. Check potatoes with a fork, taking care not to touch the sides of the steam tray or inner pot, as they will be hot. If potatoes are not completely cooked, replace cover and cook for another few minutes. Use oven mitts to remove steam tray from rice cooker and serve hot with butter, salt and pepper.

# Jambalaya

---

2 tbsp.	extra virgin olive oil
1 cup	coarsely chopped onion
1	red bell pepper, peeled and diced
1	medium stalk celery, diced
1 cup	uncooked long-grain rice
1 3/4 cups	chicken broth
1 can (14 oz)	tomato pieces with juice
1 tbsp.	tomato paste
1/2 tsp.	dried thyme
3/4 tsp.	kosher salt, or 1/2 tsp. regular salt
-	freshly ground black pepper to taste
1 pinch	powdered cloves
1/4 tsp.	prepared chili powder
1 tbsp.	dried parsley
6-8 drops	Tabasco sauce
1/3 cup	diced ham
6 oz.	smoked Polish sausage, cut into slices
6-8	medium shrimp (optional)

Heat oil in the inner pot and, using extreme caution, sauté onion, pepper, and celery for 3-4 minutes to soften (see Safety Considerations on page 15). Use a long-handled wooden spoon for stirring to avoid burning hands on the inner pot. Add rice and stir to coat. Add remaining ingredients. Close the lid and press “STEAM/COOK” button. Allow to cook, stirring once or twice, until the rice is tender and meat is cooked through. Allow jambalaya to stand for about 10 minutes before serving on warmed plates. Serves 4.

# Steamed Sweet Potatoes

---

1 lb.	sweet potatoes
-------	----------------

Peel and cut potatoes into 1-inch cubes and place in a single layer in the steam tray. Add 2 cups water to the inner pot and place in the rice cooker. Place steam tray into the inner pot, close lid, and press “STEAM/COOK” button. Steam until potatoes are tender, about 17 minutes after water boils. Test potatoes: carefully open the lid, keeping hands and face away to avoid steam burns. Using a fork, test potatoes for doneness. Take care not to touch sides of steam tray or inner pot, as they will be hot. If potatoes are not done, close lid and steam for an additional few minutes. Use oven mitts to remove steam tray from rice cooker and serve potatoes immediately with butter.

# Steamed Broccoli or Cauliflower

---

Broccoli or Cauliflower or a mixture of both

Wash broccoli/cauliflower and cut into florets or pieces with 2-3 inch stems. Place in the steam tray. Add 1-1/2 cups water to the inner pot, place inner pot into the rice cooker, close lid and press "STEAM/COOK" button. When water has reached a boil, carefully open the lid, keeping hands and face away to avoid steam burns. Using oven mitts, place steam tray with vegetables into the rice cooker, taking care not to touch sides of the inner pot, as it will be hot. Steam for 8 to 10 minutes or to desired crispness. Using oven mitts, remove steam tray from inner pot and place vegetables in a serving dish. Season with salt, pepper, butter, olive oil, or cheese if desired.

# Orange Gingered Carrots

---

1/2 lb.	carrots, peeled, sliced or cut into 3/8-inch square by 3-inch long strips
-	grated zest of 1 orange
1/2 cup	orange juice or combination of orange juice and water
2 slices	fresh ginger
1 tbsp.	butter

Add carrots and remaining ingredients to inner pot. Place inner pot into rice cooker, cover, and press "STEAM/COOK" button. Steam for 10 minutes after liquid has come to a boil. Check to see if carrots are tender by carefully opening the lid, keeping hands and face away to avoid steam burns. If carrots are not done, cover and cook for an additional 1-2 minutes, adding more water if needed. Spoon out of inner pot and serve.

## Steamed Green Beans

1 lb. green beans, stemmed

Add 2 cups water to the inner pot and place into the rice cooker, cover and press the "STEAM/COOK" button to bring to a boil. Place beans in the steam tray. When water has come to a boil, carefully open the lid, keeping hands and face away to avoid steam burns. Using oven mitts, carefully place steam tray with beans into the rice cooker. Close the lid and steam for 10 to 12 minutes or until beans are tender. Do not allow to stand on warm mode or beans will be overcooked. Using oven mitts, carefully remove steam tray from the inner pot. Spoon beans onto a platter, season with salt, pepper, and butter. Serve immediately.

## Steamed Butternut Squash

1 lb. butternut squash, peeled and cut into 1-inch cubes

Add 2 cups water to the inner pot and place into the rice cooker, cover and press the "STEAM/COOK" button to bring to a boil. Place squash in the steam tray. When water has come to a boil, carefully open the lid, keeping hands and face away to avoid steam burns. Using oven mitts, carefully place steam tray with squash into the rice cooker. Close the lid and steam for 10 to 12 minutes or until squash is tender. Do not allow to stand on warm mode or squash will be overcooked. Using oven mitts, carefully remove steam tray from the inner pot. Spoon squash onto a platter, season as desired and serve immediately.

## Sweet Corn

Fresh corn, trimmed, cut in half if needed

Remove corn husks and silk and trim as needed. Place corn ears in the steam tray. Add 1-1/2 cups water to the inner pot, place in the rice cooker, cover and press the "STEAM/COOK" button. When water has come to a boil, carefully open the lid, keeping hands and face away to avoid steam burns. Using oven mitts, place steam tray with corn into the rice cooker, taking care not to touch sides of the inner pot, as it will be hot. Steam for 10 minutes. Using oven mitts, remove the steam tray immediately. Season corn as desired and serve hot.

# Monterrey Green Chile Chicken Wraps

---

1 1/2 cups	long grain rice
3 cups	low-sodium chicken broth
4 ounce	can diced green chiles
1 small	white onion, diced
1 pound	boneless, skinless chicken breasts, cut into 1/2-inch pieces
1 tsp.	salt
1/4 tsp.	cayenne pepper
6	flour tortilla wraps
1 cup	lowfat sour cream
2 tbsp.	fresh cilantro, chopped
1 tbsp.	fresh chives, chopped
1 cup	Monterey Jack cheese, shredded

Place the rice, chicken broth and chiles in the inner pot. Stir with a long-handled plastic spoon. Add the onion, chicken meat, salt and cayenne pepper. Cover and press the "WHITE RICE" button.

While the chicken and rice cook, loosely wrap the four tortillas in a paper towel and place them in the steamer tray. Combine the sour cream, cilantro and chives in a small bowl. After the rice has steamed for 25 minutes, open the lid, keeping hands and face away to avoid steam burns, and use oven mitts to place the tortilla-filled steamer tray into the rice cooker. Steam for an additional 5 minutes. Using oven mitts, remove the tray and check the chicken with the tip of a knife to determine that the chicken is cooked through and no pink remains. Add the sour cream mixture to the rice, carefully replace the steam tray with the tortillas and steam for an additional 3 minutes.

When done, spoon the Monterrey Green Chile Chicken equally into the wraps. Layer the Jack cheese over all and wrap. Serves 4.

# Salmon with Pecan Parmesan Risotto & Asparagus Tips

---

2 cups	uncooked brown rice
1 1/2 cups	water
1 1/2 cups	sauterne cooking wine
1/2 lb.	salmon fillets
	salt and pepper to taste
1/2 lb.	fresh asparagus, cut into 1-inch pieces
1 tbsp.	extra-virgin olive oil
1/2 cup	Parmesan cheese, finely grated
2 tbsp.	pecans, chopped
1	lemon for garnish

Place the rice, water and sauterne in the inner pot. Close the lid and press the "BROWN RICE" button; steam for 1 hour and 30 minutes. Meanwhile, season the salmon with salt and pepper to taste. Place a heat-resistant plate on the bottom of the steam tray and add the salmon fillets. Arrange the asparagus around the salmon fillets as space allows. Open the lid after 1 hour and 30 minutes, keeping hands and face away to avoid steam burns, and carefully insert the steam tray with salmon and asparagus into the rice cooker (use oven mitts and avoid touching the inner pot, as it will be hot).

Close the lid and press the "STEAM/COOK" button; cook for 15 minutes. When done, check the fish and asparagus with the tip of a fork and continue steaming if needed until the fish is opaque and the asparagus is tender. When done, remove the salmon and asparagus and place each on a plate. Squeeze the lemon over the salmon.

Remove the rice from the inner pot to a bowl. Drizzle with the olive oil, add the Parmesan cheese and chopped pecans and toss thoroughly. Serve with the salmon and asparagus. Serves 2.

## Hot Spinach & Artichoke Spread

---

8 oz.	pkg. cream cheese, softened
1/4 cup	lowfat mayonnaise
3/4 cup	Parmesan cheese, grated
1 clove	garlic, minced
14 oz.	can artichoke hearts, drained and chopped
1/2 cup	frozen spinach, thawed and squeezed dry
1/2 tsp	dried Italian seasoning
1 tbsp.	fresh Italian parsley, chopped
	salt and freshly ground black pepper
4 cups	water

In a medium bowl, blend together the cream cheese, mayonnaise and Parmesan cheese. Add the garlic, artichoke hearts, spinach, Italian seasoning, parsley, salt and pepper. Mix well. Coat a 4-cup heatproof dish with nonstick cooking spray. Spoon the spread into the dish and smooth the top with a knife. Cover the top of the dish with aluminum foil. Pour the water into the inner pot and position the steam tray on top. Place the dish in the steam tray. Close the lid and press the "STEAM/COOK" button for 15 minutes. Carefully open the lid, keeping hands and face away to avoid steam burns, and check the spread. When done, it will be warm throughout. Serve with herbed crackers. Serves 6.

## Red Potato, Smoked Ham & Chive Soup

---

2-1/2 cups	chicken broth
1-1/2 cups	water
1 (5.5 oz) pk.	instant au gratin potatoes plus seasoning packet
6	baby red potatoes, rinsed and cut into small cubes
1/4 tsp.	freshly ground black pepper
1/2 cup	smoked ham, chopped (you may use lowfat turkey ham)
1 cup	half and half cream
3 tbsp.	fresh chives, chopped

Place the broth, water, instant potatoes, seasoning, potatoes and pepper in the inner pot. Close the lid and press the "STEAM/COOK" button and steam for 20 minutes. Carefully open the lid, keeping hands and face away to avoid steam burns. Use a long-handled plastic spoon to stir in the ham and cream, taking care not to touch the inner pot, as it will be hot. Close the lid and continue steaming for 3 minutes. When done, use ladle to spoon into individual bowls and garnish with the chopped chives.

Serves 4.

# Homemade Tomato Soup with Cilantro Aioli

---

2 tbsp.	butter or margarine
1 large	yellow onion, chopped
2 lbs.	ripe tomatoes, cored, peeled and cut into small pieces
1 tsp.	salt
1/2 tsp.	freshly ground black pepper
4 cups	chicken or vegetable broth
1/2 cup	lowfat milk
2 tbsp.	fresh cilantro, minced
1 tsp.	lemon juice
1/4 cup	lowfat mayonnaise

Place the butter and onions in the inner pot and sauté for 3 to 4 minutes, or until the onions are translucent (see Safety Considerations on page 15). Add the tomatoes, salt, pepper and broth. Close lid and press the “STEAM/COOK” button and steam for 30 minutes. When done, carefully open the lid, keeping hands and face away to avoid steam burns, and add the milk. Continue steaming for 3 minutes, or until the soup is heated through. If desired, puree the soup in a blender before serving. Prepare the aioli by combining the cilantro, lemon juice and mayonnaise. Blend until smooth. To serve, pour the hot soup into individual bowls and spoon the aioli in a swirl over each serving. Serves 6.

# Game Day Warm Chili & Cheese Dip

---

1 small	yellow onion, chopped
2 tsp.	vegetable oil
1 clove	garlic, minced
2 15 oz.	cans prepared chili without beans
1 cup	prepared medium salsa
1/2 cup	black olives, sliced
3 oz.	lowfat cream cheese, cubed
3 oz.	cheddar cheese, grated
	tortilla chips

Place the onion, oil and garlic in the inner pot and sauté for 3 minutes (see Safety Considerations on page 15). Use a large wooden spoon to gently stir as the onion and garlic cook. Add the chili, salsa, olives, cream cheese and cheddar cheese. Stir to combine all of the ingredients, close the lid, and press the “STEAM/COOK” button. Steam for 4 minutes. Carefully open the lid, keeping hands and face away to avoid steam burns, and stir the dip. Steam again for 3 minutes. Open the lid and stir again. Continue steaming until the dip is warm throughout and the cheeses are melted. When done, serve in a large bowl and use the tortilla chips for dipping. Serves 6.

## Spinach & Mushroom Breakfast Frittata

---

1/2 cup	frozen spinach, thawed, drained and squeezed dry
1/2 cup	fresh button mushrooms, cleaned and sliced
2	green onions, chopped
4 large	eggs, beaten (you may use egg substitute)
1/2 tsp.	ground oregano
1/2 tsp.	ground thyme
pinch	salt and freshly ground black pepper
1/4 cup	Asiago cheese, grated (you may use Parmesan cheese)

Coat the inner pot with nonstick cooking spray. In a medium bowl, mix together the spinach, mushrooms and onions. Add the eggs, oregano, thyme, salt, pepper and cheese. Mix well until all ingredients are combined. Spoon the frittata into the inner pot. Close the lid and press the "STEAM/COOK" button and steam for 12-14 minutes. When done, the eggs should be firm on the bottom and almost set on the top. Use a plastic spatula to slice the frittata into wedges and serve. Serves 4.

## Yukon Gold Potato & Egg Scramble

---

3 medium	Yukon Gold potatoes, cleaned and cut into 1-inch pieces
2 cups	water
4 large	eggs, beaten
pinch	salt and freshly ground black pepper
1/2 cup	Gouda cheese, shredded
1	green onion, chopped

Coat the inner pot with nonstick cooking spray. Place the potatoes in the bottom of the inner pot and cover with the water. Close the lid, press the "STEAM/COOK" button and steam for 25 minutes. When done, use oven mitts to remove inner pot from the rice cooker and carefully strain out the remaining water. Replace the inner pot and potatoes in the rice cooker and pour the eggs over the potatoes. Sprinkle with the salt and pepper. Layer with the Gouda cheese and green onion. Close the lid, press the "STEAM/COOK" button and steam for 12-14 minutes, or until the eggs are firm around the edges and the top is almost set. Let stand for 2 minutes. Spoon onto 4 individual plates. Serves 4.

## Breakfast Oatmeal

1-1/3 cups	rolled oats (not quick cooking)
2 cups	apple juice
3/4 cup	water
1/3 cup	raisins
1 dash	salt

Add ingredients to the inner pot and stir. Place inner pot into the rice cooker, cover and press the "STEAM/COOK" button. Halfway through the steaming cycle, carefully open the lid, keeping hands and face away to avoid steam burns and stir. Cover and continue cooking until the rice cooker switches to keep warm mode. Allow to stand for 10 minutes before serving.

## Wine-Poached Pears

4	small to medium pears, firm but ripe
2 cups	white wine (Reisling is suggested)
1/2 cup	sugar
1/2 tsp.	vanilla
-	whipped cream and toasted sliced almonds for garnish (optional)

Peel pears and remove core from bottom. Cut a slice from the bottom of each pear to form a flat base. Leave stem on top of pear. Add wine and sugar to the inner pot, and place inner pot into the rice cooker. Dip the pears into the wine mixture to coat, and lay them on their sides in the steam tray. Place the steam tray into the rice cooker, cover and press the "STEAM/COOK" button. Steam for about 20 minutes or until cooked (when the tip of a knife goes in easily). If pears are still firm, cook for another 3-5 minutes. Turn off the cooker. Using oven mitts, carefully remove steam tray from the rice cooker, taking care not to touch the sides of the inner pot, as it will be hot. Place steam tray aside and allow to cool. When pears are cool enough to handle, move them to a bowl. Add vanilla to liquid and pour over the pears. Chill for 1-2 hours or overnight in the refrigerator. Serve with whipped cream and toasted sliced almonds.

\*For a dramatic pink blush, use red wine instead of white.

# Double Lemon Glazed Sponge Cake

---

	Nonstick cooking spray
1 cup	cake flour
1/2 tsp.	salt
1 tsp.	baking powder
3	eggs, beaten
1 cup	sugar
2 tbsp.	lemon juice, divided
1/2 tsp.	lemon extract
6 tbsp.	milk
1 cup	powdered sugar

Coat a heatproof 1-1/2 quart soufflé dish with nonstick cooking spray. In a medium bowl, sift together the flour, salt and baking powder. Set aside. In a large bowl, beat the eggs with the sugar until very smooth. Add 1 tablespoon of the juice, extract and milk and beat for 2 minutes on medium speed. Add the dry ingredients gradually and beat again for 2 minutes on medium speed.

Pour the batter into the dish, leaving 1/2-inch space at the top. Fill the inner pot with water to the 4-cup line. Place the soufflé dish in the water, making sure that the water does not go over the top of the dish. Press the “STEAM/COOK” button and cook for 25 minutes.

Carefully open the lid, keeping hands and face away to avoid steam burns, and check the water level. If it is below 1 cup, add water to the 3-cup level, cover and continue cooking for 20 minutes. Check the cake when done; it should be just dry on top. Using oven mitts, carefully remove the cake from the cooker and place on a rack to cool.

Prepare the glaze by combining the lemon juice with the powdered sugar. Drizzle the glaze over the sponge cake and serve at once. Serves 4 to 6.

# LIMITED WARRANTY

Aroma Housewares Company warrants this product free from defects in material and workmanship for one year from provable date of purchase in the continental United States.

Within this warranty period, Aroma Housewares Company will repair or replace, at its option, defective parts at no charge, provided the product is returned, freight prepaid with proof of purchase and U.S. \$14.00 for shipping and handling charges payable to Aroma Housewares Company. Before returning an item, please call the toll free number below for a return authorization number. Allow 2-4 weeks for return shipping.

This warranty does not cover improper installation, misuse, abuse or neglect on the part of the owner. Warranty is also invalid in any case that the product is taken apart or serviced by an unauthorized service station.

This warranty gives you specific legal rights which may vary from state to state and does not cover areas outside the United States.

AROMA HOUSEWARES COMPANY  
6469 Flanders Drive  
San Diego, California 92121  
1-800-276-6286  
M-F, 8:30 AM - 5:00 PM, Pacific Time  
Website: [www.aromaco.com](http://www.aromaco.com)