

AROMA®

6-in-1 SuperPot™



Instruction Manual & Recipes

Model ASP-137

Congratulations!

Your **AROMA** SuperPot™ will become one of the most exciting appliances in your home. This product has been designed to be extremely versatile. It can be used as a skillet, steamer, slower cooker, stir fryer, Sukiyaki cooker, or warmer.

Please read the following instructions carefully before your first use.

Published By:

Aroma Housewares Co.
6469 Flanders Drive
San Diego, CA 92121
U.S.A.
1-800-276-6286
www.aromaco.com

© 2005 Aroma Housewares Company. All rights reserved.

IMPORTANT SAFEGUARDS

Basic safety precautions should always be followed when using electrical appliances, including the following:

1. Read all instructions.
2. Do not touch hot surfaces. Use handles or knobs.
3. To protect against electrical shock, do not immerse electrical cord in water or other liquid.
4. Close supervision is necessary when any appliance is used by or near children.
5. Unplug from outlet when not in use and before cleaning. Allow the appliance to cool before putting on or taking off parts and before cleaning the appliance.
6. Do not operate any appliance with a damaged cord or plug or after the appliance malfunctions or has been damaged in any manner. Return appliance to the nearest authorized service facility for examination, repair, or adjustment.
7. The use of accessory attachments not recommended by the appliance manufacturer may result in fire, electric shock, or injury.
8. Do not use outdoors.
9. Do not let the cord touch hot surfaces or hang over the edge of a counter or table.
10. Do not place on or near a hot burner or in a heated oven.
11. Extreme caution must be used when using or moving an appliance containing hot oil or other hot liquids.
12. Do not use the appliance for other than intended use.
13. Always attach the plug to the appliance first, and then plug the cord into the wall outlet. To disconnect, turn any control to "OFF" then remove the plug from the wall outlet.

SAVE THESE INSTRUCTIONS

SHORT-CORD INSTRUCTIONS

1. A short power-supply cord is provided to reduce risk resulting from becoming entangled in or tripping over a longer cord.
2. Longer extension cords are available and may be used if care is exercised in their use.
3. If a longer extension cord is used:
 - a. The marked electrical rating of the extension cord should be at least as great as the electrical rating of the appliance.
 - b. The longer cord should be arranged so that it will not drape over the counter top or tabletop where it can be pulled by children or tripped over unintentionally.

POLARIZED PLUG

This appliance has a **polarized plug** (one blade is wider than the other); follow the instructions below:

To reduce the risk of electric shock, this plug is intended to fit into a polarized outlet only one way. If the plug does not fit fully into the outlet, reverse the plug. If it still does not fit, contact a qualified electrician. Do not attempt to modify the plug in any way.

This appliance is for household use only.

PARTS IDENTIFICATION

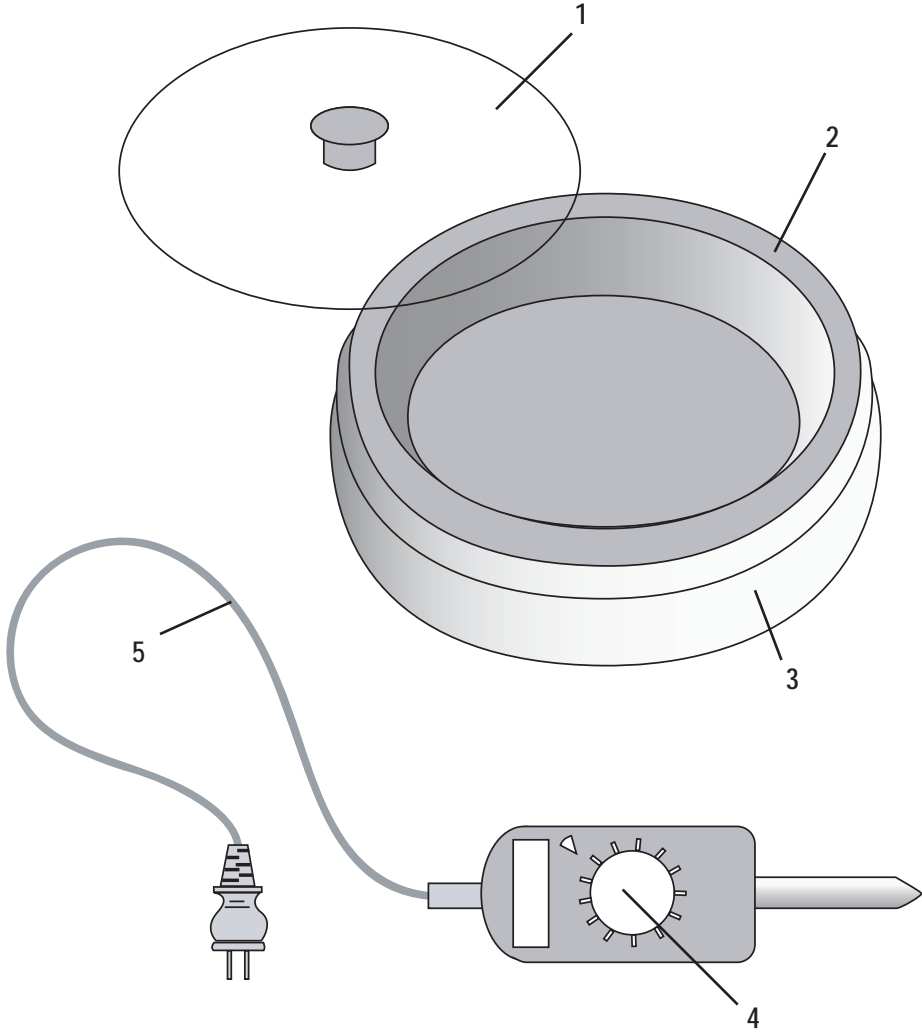

1. Tempered Glass Lid
2. Premium Non-stick Cooking Pot
3. Cool-Touch Body
4. Adjustable Temperature Dial
5. Short Power-Supply Cord

HOW TO USE

1. Remove all packaging materials.
2. Pull the cooking pan away from the plastic base.
3. Wash the cooking pan, base, and lid with warm soapy water using a sponge or dishcloth.
4. Rinse thoroughly to remove soap residue.
 - **Do not use abrasive cleaners or scouring pads.**
 - **Never immerse the power cord.**
5. Condition the non-stick surface with oil or vegetable shortening.
6. Turn temperature selector to "OFF." Plug the power cord to the appliance first, and then plug cord into the wall outlet.
7. Turn the knob to the desired setting. The red indicator light will illuminate.
8. The light will go off when the cooking pan has reached the selected temperature.
9. When finished, turn the knob to the "OFF" position and unplug the power plug.

NOTE:

- During operation, the light will turn on and off, indicating the proper temperature is being maintained.
- Wooden, heatproof plastic, and nylon utensils are recommended. Metal utensils may scratch the non-stick surface.

HOW TO CLEAN

AFTER USE

1. Disconnect the plug from the wall outlet, then remove the power cord from the appliance.
 2. Allow the unit to completely cool.
 3. Pull the cooking pan away from the plastic base.
 4. Wash the cooking pan, base, and lid with warm soapy water, using a sponge or dishcloth.
 5. Rinse thoroughly to remove soap residue.
- **This appliance can be completely immersed in water.**
 - **Never immerse the power cord.**
 - **Do not use abrasive cleaners or scouring pads.**

RECIPES

SUKIYAKI COOKING

Sukiyaki is a traditional Japanese dish with meat and an assortment of vegetables served with rice. It is usually done in a deep skillet and prepared right at the dining table. Tasty, nutritious, and fun, Sukiyaki is perfect for a romantic dinner for two, or even a small family gathering.

BEEF SUKIYAKI

1.5 lbs. Beef (roast)

1 Onion

1/2 Head of Chinese Cabbage

2 or 3 Green Onions

4 Fresh Shiitake Mushrooms

1 pkg. Tofu

5 Tbsp Sugar

5 Tbsp. Japanese Rice Vinegar

4 Tbsp. Soy Sauce

Cut the beef into thin slices and cut the onion in half. For each onion half, cut into five or six slices. Cut the green onions into two-inch sections. Remove the stems from the Shiitake mushrooms. Cut the tofu into two-inch cubes, and cut the cabbage into bite-size pieces.

Heat up the Sukiyaki pot. Cook the beef evenly on both sides. Do not overcook. Add the ingredients in this order: Japanese rice vinegar, sugar, then soy sauce to taste. Put in half of the ingredients. Cook for three to five minutes or until the food is cooked. Serve directly out of the pot. Do not over cook. Add in the remaining ingredients. Enjoy the dish immediately.

RECIPES

GRILLING

Grilling is easy, and the flavor is enhanced by caramelized grill markings. Juiciness, speed of cooking, and lower fat content make grilling an essential part of a healthy lifestyle.

CHICKEN SHISH-KEBABS

- 1 pkg. Bamboo Skewers (or metal)
- 1 lb. Boneless, Skinless Chicken Breasts
- 1 Sweet Yellow Onion
- 1 Red or Green Bell Pepper
- 1 Can Pineapple Chunks
- 20 pcs. Large Mushrooms
- 2 cups Marinade or BBQ sauce

Cut the chicken breasts and vegetables into one-inch by one-inch pieces. Alternate the chicken and the vegetables onto the skewers. Apply the sauce to both sides of the skewers using a basting brush.

Heat the pan to 350° - 375°. Place two to three shish-kebabs into the pan. Cook each kebab for approximately three to five minutes on each side. When cooked, place the skewers on a serving plate or a bed of rice.

HELPFUL HINTS

For more flavorful shish-kebabs, let them soak in the marinade or BBQ sauce overnight in the refrigerator.

RECIPES

SLOW COOKING

A hearty bowl of soup or stew is always welcome at any table. Be creative and use various left-over meats and vegetables with your favorite stock and create your own unique recipes. When preparing soup or stew, try to allow extra time for it to simmer. This will allow flavors to blend and meat to be more tender.

HELPFUL HINTS

To thicken your stew, mix 1/4 cup of flour with enough water to form a thin paste. Gradually add it to the stew, stirring until thickened. If using fresh parsley or herbs in your recipe, add them in the last few moments of cooking to preserve flavor. Save any left-overs for the next day. The flavors will increase overnight in your refrigerator. Canned stew tomatoes or water with bouillon seasoning and spices added will make great stock-starters for soups and stews.

RECIPES

VEGETARIAN SOUP

2 Tbsp. Peanut Oil
6 cups Water
1 Small Cabbage
1 Tbsp. Soy Sauce
1/2 cup Carrots
1 tsp. Sherry
3 Celery Stalks
1 tsp. Salt
1 Scallion
Dash of Pepper

Cut the cabbage, carrots, celery, and scallion into strips. Heat the oil in the pot, add the vegetables and stir-fry until they begin to soften – about two to three minutes. Add the water, soy sauce, sherry, salt, pepper, and vegetables to the cooking pot. Cook at 250° to 275° for two hours.

RECIPES

BRAISED ABALONE MUSHROOM

- 10 pcs. Dried Abalone (soak overnight)
- 5 pcs. Dried Scallops
- 15 pcs. Black Mushrooms
- 15 pcs. Button Mushrooms
- 2 Tbsp. Oyster Sauce
- 2 1/2 cups Water
- 2 Tbsp. Oil
- 6 pcs. Garlic (crushed)
- 1 1/2 tsp. Corn Flour (for thickening)

Combine all ingredients into the slow cooker. Set the temperature at 250° to 275° for two hours, change the temperature to 200° for four to six hours. To serve, thicken it with corn flour and garnish with a Spring onion and parsley.

RECIPES

STIR-FRYING

Stir-frying has quickly become a mainstay in many diets. It is a fast, easy, and delicious way to prepare an endless variety of foods. By quickly cooking food at high heat, both juices and nutrients are retained.

Try combining your favorite meat, chicken, or shrimp with a mixed variety of vegetables and serve for a real treat. Often times, odds and ends you have in your refrigerator can make an excellent stir-fry meal.

HELPFUL HINTS

Add your ingredients that take the longest to cook first, then add remaining ingredients, if any. Rapidly stir the food until cooked according to your recipe. We recommend using wooden utensils for best results and to protect your inner pot surface. Add your sauce ingredients and mix well in the last few moments. Serve hot.

RECIPES

CHICKEN STIR-FRY

- 1 lb. Boneless/Skinless Chicken Breast (cut into 1/2-inch strips)
- 2 Tbsp. Lime Juice
- 2 tsp. Chili Powder
- 1 cup Fresh Mushrooms
- 1 cup Bell Pepper, Red or Green (cut into thin slices)
- 2 Tbsp. Vegetable Oil
- 1/3 cup Picante Sauce
- 2 Tbsp. Chopped Fresh Cilantro
- 1 Medium Tomato (chopped)

Mix lime juice and chili powder in a medium bowl and stir in the chicken strips. Cover and refrigerate this mixture for one hour.

Heat the pot to 325°. Using one tablespoon of the oil, stir-fry the chicken with the marinade until the chicken is white, then remove the chicken from the pot. Using the remaining tablespoon of oil, stir-fry the mushrooms and bell pepper for two to three minutes or until crispy but tender. Stir in the chicken, picante sauce, and cilantro.

RECIPES

STEAMING

Steam cooking is one of the easiest, most healthful and convenient methods of cooking. It allows you to preserve more flavor, texture, vitamins, and nutrients than other cooking methods.

HELPFUL HINTS

All vegetables should be thoroughly cleaned and washed before steaming. Thin, leafy vegetables such as cabbage do not require as much water as root vegetables, such as carrots or turnips. You might want to use a heat-resistant plate or metal rack with items being steamed. Do not remove the lid during steaming, as moisture will escape and the cooking time will have to be extended.

RECIPES

STEAMED BEEF WITH BROCCOLI

1 lb. Beef (sliced thin against the grain)

MARINADE

2 tsp. Soy Sauce

1/2 tsp. Sugar

1 tsp. Minced Ginger Root

1 tsp. Sesame Oil

1 cup Broccoli Floret

1 tsp. Wine

1 clove Garlic (minced)

1 tsp. Cornstarch

1 tsp. Oyster Sauce

Combine the sliced beef with the marinade in a plate. Put one cup of water in the pot, then place the plate in the cooker. Steam for 10 minutes. Open the lid and arrange the broccoli around the outer edge of the plate. Cover and steam for an additional 10 minutes.

LIMITED WARRANTY

Aroma Housewares Company warrants this product free from defects in material and workmanship for one year from provable date of purchase in continental United States.

Within this warranty period, Aroma Housewares Company will repair or replace, at its option, defective parts at no charge, provided the product is returned, freight prepaid with proof of purchase and U.S. \$6.00 for shipping and handling charges payable to Aroma Housewares Company. Before returning an item, please call the toll free number below for return authorization number. Allow 2-4 weeks for return shipping.

This warranty does not cover improper installation, misuse, abuse or neglect on the part of the owner. Warranty is also invalid in any case that the product is taken apart or serviced by an unauthorized service station.

This warranty gives you specific legal rights and which may vary from state to state and does not cover areas outside the United States.

AROMA HOUSEWARES COMPANY
6469 Flanders Drive
San Diego, California 92121
1-800-276-6286
M-F, 8:30 AM - 5:00 PM, Pacific Time
Website: www.aromaco.com