

AROMA®



instruction manual

AHP-303

Single Burner Hot Plate

Questions or concerns about your Aroma product?

www.AromaCo.com/Support

1-800-276-6286

**DISCOVER
more of our
products!**



Multicookers/
Rice Cookers



Pressure Cookers



Water Kettles



Indoor Grills



Induction Cooktops

AROMA®

To Enhance and Enrich Lives.

Here at Aroma we strive to make a difference—to design and distribute products that enhance and enrich people's lives.

Aroma offers an array of exceptional products to make cooking simple and satisfying. Discover other countertop appliances and cookware from our current product lineup to complement your kitchen.

Stay connected for more recipe ideas and monthly giveaways!



www.AromaTestKitchen.com



[/AromaHousewares](https://www.instagram.com/AromaHousewares)



Published By:

Aroma Housewares Co. | 6469 Flanders Drive, San Diego, CA 92121, U.S.A.

1-800-276-6286 | www.AromaCo.com

©2019 Aroma Housewares Company | All rights reserved.



IMPORTANT SAFEGUARDS

Basic safety precautions should always be followed when using electrical appliances, including the following:

- Important: Read all instructions carefully before first use.**
- Do not touch hot surfaces. Use handles or knobs.
- To protect against electrical shock, fire, and injury to persons, do not immerse cord, plug or the appliance itself in water or any other liquid. See instructions for cleaning.
- Close supervision is necessary when the appliance is used by or near children. This appliance is not intended for use by children.
- Prior to plugging appliance into the wall outlet, ensure temperature control switches are set to "OFF" (•••) position. To disconnect completely, set temperature control dial to ".••" and unplug the hot plate.
- Unplug from the wall outlet when not in use and before cleaning. Allow unit to cool completely before cleaning the appliance.
- Do not operate any appliance with a damaged cord or plug or after the appliance malfunctions or has been damaged in any manner. Contact Aroma customer service for examination, repair or adjustment.
- Using attachments or accessories other than those supplied by Aroma Housewares can create a hazard. Do not use incompatible parts.
- Do not use outdoors.
- Do not let cord hang over the edge of table or counter, or touch hot surfaces.
- Do not place on or near a hot burner or in a heated oven.
- Do not use appliance for other than its intended use.
- Do not clean with metal scouring pads. Pieces may break off the pad and damage electrical parts, creating a risk of electric shock. Metal-scouring pads may damage the steel finish.
- When in use, keep hot plate a minimum of 10-12 inches away from walls. Place on a stable, heat-resistant surface and in a well-ventilated area. Place the appliance on a dry and horizontal surface.
- A fire may occur if the hot plate is covered or touching flammable material, such as curtains, draperies, walls and the like, while in operation.
- Do not place any flammable materials in or on the hot plate, such as paper, cardboard, plastic, etc.
- To ensure an optimum performance life for the hot plate, avoid dropping any food on the heating element.
- Always unplug from the plug gripping area. Never pull on the cord.
- If the electric circuit in use is overloaded with other appliances, this appliance may not operate properly. The appliance should be operated on a separate electrical circuit from other operating appliances.
- Clean the appliance regularly, as a build-up of grease poses a fire hazard.
- Always allow the appliance to cool completely before cleaning.
- Do not attempt to move the appliance with cookware on top.
- Do not plug in or operate with wet hands.
- Intended for countertop use only.

SAVE THESE INSTRUCTIONS



IMPORTANT SAFEGUARDS

(CONT.)

Short Cord Instructions

1. A short power-supply cord is provided to reduce the risks resulting from becoming entangled in or tripping over a longer cord.
2. Longer extension cords are available and may be used if care is exercised in their use.
3. If a longer extension cord is used:
 - a.) The marked electrical rating of the extension cord should be at least as great as the electrical rating of the appliance.
 - b.) The longer cord should be arranged so that it will not drape over the counter top or tabletop where it can be pulled by children or tripped over unintentionally.

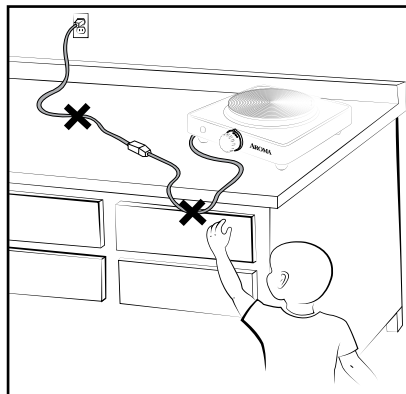

**DO NOT
DRAPE CORD!**

**KEEP AWAY
FROM CHILDREN!**

Polarized Plug

This appliance has a polarized plug (one blade is wider than the other); follow the instructions below:

To reduce the risk of electric shock, this plug is intended to fit into a polarized outlet only one way. If the plug does not fit fully into the outlet, reverse the plug. If it still does not fit, contact a qualified electrician. Do not attempt to modify the plug in any way.

If the supply cord is damaged, it must be replaced by the manufacturer, its service agent or a similarly qualified person in order to avoid a hazard.

**THIS APPLIANCE IS FOR
HOUSEHOLD USE ONLY.**

Parts Identification

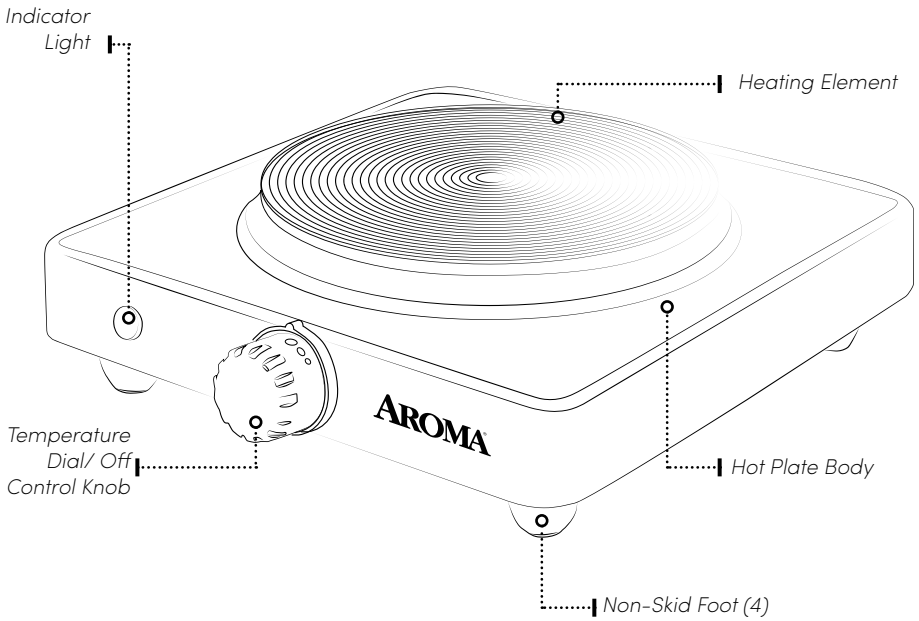

Controls/Functions

Temperature Dial/ Off Control Knob

Sets temperature to desired heat and turns the heating element off (•••).

BEFORE FIRST USE

1. **Read all instructions and important safeguards.**
 2. Remove all packaging materials and check that the item has been received in good condition.
 3. In a well ventilated area, turn the hot plate ON to the highest heat setting without any food or material on it. Let run for about 15 minutes to burn off any residue left from the manufacturer. Some odor and smoke is normal. Once ran for 15 minutes, turn off. (See Side Note)
 4. Place the hot plate on a flat, sturdy and heat-resistant surface.
 5. Set the temperature control knob to the “. . .” position.
 6. Plug the hot plate into an available wall outlet.
 7. Without placing any pots or pans on the hot plate, turn the **Temperature Control Knob** to **HIGH** for 8 to 10 minutes to heat the unit thoroughly.
-

TO CLEAN

1. **Always unplug unit and allow to cool completely before cleaning.**
 2. Turn the temperature control knob to the “. . .” position and then unplug the appliance.
 3. Wait for the hot plate to cool completely before cleaning.
 4. Clean the body of the hot plate with a damp cloth using a non-abrasive household detergent. Wipe it thoroughly clean.
 5. Clean the cooking plate surface with household cleaning powder and wipe clean with a damp cloth. Let it dry before its next use.
 6. Commercial cleaners made specifically for hot plates are recommended as they help preserve the original finish of the hot plate.
-

POTS AND PANS TO USE

1. For the most efficient operation of the hot plate, use pots and pans that are in good condition. They should have a solid and flat base to ensure proper contact with the heating element.
 2. Use pots and pans whose bottoms have diameters between 6 ½” to 7” and with a maximum cooking capacity of 1 ½ quarts.
-

Note:

IMPORTANT! The initial start should be the only time the hotplate is turned ON without a cooking utensil on it.

- Do not use harsh or abrasive cleaners.
- Do not immerse any part of appliance or power cord in water or any other liquid.
- The electric burner is **NOT** dishwasher safe and must be wiped only.
- The appliance might smoke in the first ten minutes heating.
- Any other servicing should be performed by Aroma® Housewares

USING THE HOT PLATE

1. Place the pot or pan to be used onto the hot plate.
2. Plug the power cord into an available 120V AC wall outlet.
3. Turn the temperature control knob to the desired setting.
4. Cook food as instructed by the recipe.
5. After cooking is finished, turn the temperature control knob to the “. • •” position and unplug.
.....

Temperature Guide

Setting	
1 - (Warm)	Great for keeping cooked foods at an ideal temperature for serving.
2 - 3 (Low)	Use for simmering, stewing, slow cooking, poaching, braising and applying gentle heat to foods that can burn or scorch easily, such as cream based sauces, delicate meats and seafood.
3 - 4 (Medium)	Ideal for pan frying, deep frying foods like chicken wings and potato wedges, and it's also the perfect setting for cooking soups.
5 (High)	Use the this setting when sautéing or stir frying, bringing water to a boil, in preparation for soups or stock or for steaming foods such as artichokes and broccoli.

Note:

- Do not use pots and pans with uneven bottoms for cooking on the hot plate.
- Never heat food directly on the hot plate as doing so will pose a risk of fire or electric shock.
- The hot plate must be turned to “. • •” position and disconnected from power when not in use.
- The pots and pans to be used on the hot plate should not extend beyond the hot plate itself or prevent access to the temperature control knob.



Caution:

Do not touch the heating element or the body of the hot plate while in operation as it will be extremely hot.

The hot plate heating element will remain hot for some time, even after it has been turned to the “. • •” position. Always wait for the hot plate to cool completely before cleaning or storing. Do not immerse the hot plate in any liquid. Do not allow the power cord to come in contact with any hot surfaces on the hot plate. Do not leave the hot plate unattended while in operation. Avoid dripping liquids on the surface of the hot plate while cooking.

RECIPES

Creamy Chicken with Pasta

4	boneless, skinless chicken breasts
1 cup	diced onions
2	minced shallots
2 tbsp	extra virgin olive oil
½ cup	heavy cream (or half and half)
2 tbsp	finely chopped fresh tarragon
1 tsp	white wine
8 oz.	angel hair pasta (cooked)
½ tsp	fresh ground pepper (plus additional pepper to season the chicken)

Heat the olive oil in a skillet on **HIGH**. Season both sides of each chicken breast with salt and pepper. Cooking in batches, brown the chicken breasts on each side (about 5 to 8 minutes per side). Remove the chicken breasts as soon as the meat is cooked through. After removing the chicken breasts, add onions, shallots and white wine to the skillet and cook until the onions become soft and translucent. Add cream, salt, pepper, and tarragon to the skillet and cook for an additional 5 to 7 minutes. (Add ½ cup of chicken stock if more liquid is desired). Place the cooked chicken breasts on the cooked pasta and ladle the cream sauce over the chicken and pasta.

SERVES 4.

.....

Santa Fe Chicken with Salsa

4	boneless, skinless chicken breasts
½ tsp	red chili powder
½ tsp	salt
1 tsp	cumin
2 - 3	limes
1 tsp	fresh grated ginger
½ jar	medium salsa
¼ cup	finely chopped cilantro

Squeeze limes over the chicken breasts. Season both sides of each breast with chili powder, salt, cumin and ginger.

RECIPES (CONT.)

Allow the chicken to rest for 30 minutes in the refrigerator. Bring a skillet to high heat and brown the chicken breasts on each side in batches (about 5 to 8 minutes per side). After the meat has cooked through, remove the breasts and cut into strips. Serve topped with salsa and cilantro.

SERVES 4.
.....

Spicy Skirt Steak

1 ½ lbs	skirt steak (trimmed of fat)
2 tbsp	finely minced garlic
1 can	crushed tomatoes (15 ½ oz)
¼ cup	chopped cilantro

Steak Marinade

2 tbsp	extra virgin olive oil
2 tsp	brown sugar
2 tsp	fresh ground pepper
2	jalapeños
2 tsp	ground cinnamon
2 tbsp	lime juice

Mix the ingredients for the marinade together in a large bowl. Place the skirt steak in the mixture and allow the steak to marinate for at least 2 hours in the refrigerator (it will be more flavorful if left overnight). Heat the olive oil in a skillet on high heat. Carefully transfer the steak to the skillet and brown both sides (approximately 3 minutes per side). Once the steak reaches the desired doneness, remove the steak and add the garlic and tomatoes to the skillet.

Allow the tomatoes and garlic to simmer on **MEDIUM** for 2 minutes. Slice the steak thinly across the grain. Serve hot, topped with tomato sauce and cilantro.

SERVES 4.
.....

RECIPES (CONT.)

Spring Vegetable Sauté

2 tbsp	extra virgin olive oil
3	shallots (cut crosswise into thin slices)
½ lb	sugar snap peas
1 lb	asparagus
1 can	lima beans (15 oz. drained of juices)
1 can	corn kernels (15 oz. drained of juices)
1 tsp	lemon juice
½ tsp	minced lemon zest
1 tsp	salt

Wash and dry the asparagus. Using a vegetable peeler, shave the skin off of the bottom half of each stalk. Cut the asparagus diagonally into slices roughly ½ inch wide. Wash the sugar snap peas. Trim and remove strings. Heat 1 tbsp of olive oil in a skillet on **MEDIUM-HIGH** heat. Sauté the shallots until they are tender. Remove the shallots. Turn the heat to **HIGH**. Add the snap peas along with ½ tsp of salt and sauté until tender. Return the shallots to the skillet and add the remaining 1 tbsp of olive oil with the asparagus and ½ tsp of salt. Sauté until the asparagus is tender. Add the corn and lima beans and stir for 1 to 2 minutes. Add lemon zest and lemon juice. Stir to thoroughly heat.

SERVES 4.
.....

LIMITED WARRANTY

Aroma Housewares Company warrants this product against defects in material and workmanship for one year from provable date of purchase in the United States.

Within this warranty period, Aroma Housewares Company will repair or replace, at its discretion, defective parts at no charge, provided the product is returned, freight prepaid with proof of purchase and U.S. \$25.00 for shipping and handling charges payable to Aroma Housewares Company. Before returning an item, please call the toll free number below for a return authorization number. Allow 2-4 weeks for return shipping.

This warranty does not apply if the warranty period expired; the product has been modified by any unauthorized service center or personnel; the defect was subject to abuse, improper use not conforming to product manual instructions, or environmental conditions more severe than those specified in the manual and specification, neglect of the owner or improper installation; the defect was subject to Force Majeure such as flood, lightning, earthquake, other natural calamities, war, vandalism, theft, brownouts or sags (damage due to low voltage disturbances).

This warranty gives you specific legal rights, which may vary from state to state, and does not cover areas outside of the United States.

.....

SERVICE & SUPPORT

In the event of a warranty claim, or if service is required for this product, please contact Aroma® customer service toll-free at:

1-800-276-6286

M-F, 8:30am-4:30pm, Pacific Time

Or we can be reached online at:

CustomerService@AromaCo.com

For your records, we recommend stapling your sales receipt to this page along with a written record of the following:

· Date of Purchase:

· Place of Purchase:

.....

Aroma Housewares Company
6469 Flanders Drive, San Diego, CA 92121, U.S.A.

1-800-276-6286 | www.AromaCo.com

M-F, 8:30am – 4:30pm, Pacific Time

Note:

· Proof of purchase is required for all warranty claims.



To Enhance and Enrich Lives.



www.AromaCo.com