

AROMA®

*ELECTRIC
Portable Range*



Instruction Manual & Recipes

Model: AHP-303

Congratulations on your purchase of Aroma Hot Plate
It will surely become your most versatile and practical
appliances in your home.

Enjoy it!

Please read all instructions before your first use.



Published By:

Aroma Housewares Co.
6469 Flanders Drive
San Diego, CA 92121
U.S.A.
1-800-276-6286
www.aromaco.com

IMPORTANT SAFEGUARD

1. Important: Read all instructions carefully before using.
2. Do not touch hot surfaces. Use handles or knobs.
3. To protect against electrical shock, do not immerse cord, plug or the appliance itself in water or other liquid.
4. Close supervision is necessary when the appliance is used near children.
5. Prior to plugging appliance into the wall outlet, ensure temperature control switches are set to OFF position. To disconnect completely, set temperature control slide to OFF and unplug the hot plate.
6. Unplug from outlet when not in use and before cleaning. Allow unit to cool before putting on or taking off parts, and before cleaning the appliance.
7. Do not operate any appliance with a damaged cord or plug or after the appliance malfunctions or has been damaged in any manner. Return appliance to the nearest authorized service facility for examination, repair or adjustment.
8. Using attachments or accessories other than those supplied by the manufacturer can create a HAZARD. DO NOT use incompatible parts.
9. Do not use outdoors.
10. Do not let cord hang over edge of table or counter, or touch hot surfaces.
11. Do not place on or near a hot burner or in a heated oven.
12. Do not use the appliance for other than intended use.
13. Do not clean with metal scouring pads. Pieces can break off the pad and touch electrical parts, creating a risk of electric shock. Besides, metal-scouring pads may damage rotisserie finish.
14. When in use, keep oven a minimum of 10-12 inches away from walls & clear on top. Place on a stable, heat-resistant surface and in a well-ventilated area. Place the appliance on a dry and horizontal surface.
15. A fire may occur if the hot plate is covered or touching flammable material, such as curtains, draperies, walls, and the like **when in operation**.

SAVE THESE INSTRUCTIONS

16. Do not place any of the following or similar materials in or on the hot plate: such as: paper, cardboard, plastic, etc.
17. For long-life performance of the hot plate, avoid dropping any on the heating element.
18. Always pull the plug out from the wall outlet. Never pull the cord.
19. Electric Power: If the electric circuit is overloaded with other appliances, this appliance may not operate properly. The Toaster Oven/Broiler should be operated on a separate electrical circuit from other operating appliances.
20. Clean the appliance regularly as built-up of grease may cause fire.
21. ALWAYS ALLOW THE APPLIANCE TO COOL BEFORE CLEANING.

SAVE THESE INSTRUCTIONS

SHORT CORD INSTRUCTION

1. A short power-supply cord is provided to reduce risks resulting from becoming entangled in or tripping over a longer cord.
2. Longer extension cords are available and may be used if care is exercised in their use.

If a longer extension cord is used:

The marked electrical rating of the extension cord should be at least as great as the electrical rating of the appliance.

The longer cord should be arranged so that it will not drape over the counter top or tabletop where it can be pulled on by children or tripped over unintentionally.

POLARIZED PLUG

This appliance has a polarized plug (one blade is wider than the other) follow the instructions below:

To reduce the risk of electric shock, this plug is intended to fit into a polarized outlet only one way. If the plug does not fit fully into the outlet, reverse the plug. If it still does not fit, contact a qualified electrician. Do not attempt to modify the plug in any way.

This appliance is for house hold use only.

PARTS IDENTIFICATION

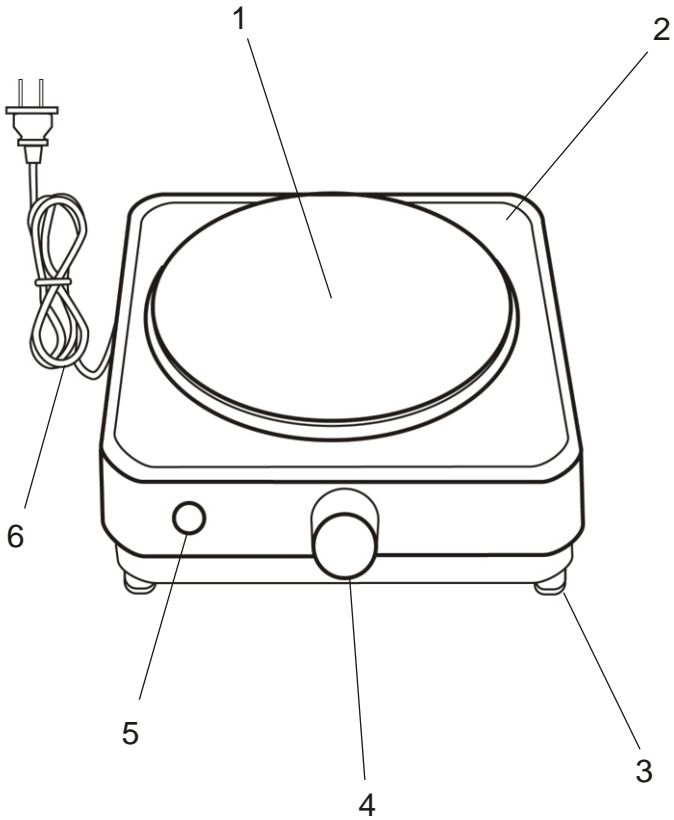

1. Hot plate heating element
2. Black enamel finish body
3. Non-skid feet
4. Temperature and OFF control
5. ON indicator light
6. Power cord and plug

HOW TO USE & CLEAN

BEFORE USING THE FIRST TIME

1. Place the hot plate in a flat and sturdy surface.
2. Set temperature control knob to OFF position.
3. Plug in the hot plate into wall outlet.
4. Before your first use, turn the temperature control to high for 3 to 5 minutes to warm up the unit. Do not place any pots and pans on it yet. You may follow this step only before the first time using the hot plate.

CHOOSE THE RIGHT POTS AND PANS

1. For the most efficient operation of the hot plate, the pots and pans that you use must be in good shape: having a solid base, the bottom of pans should be flat and even for maximum heat efficiency.
2. We suggest that the diameter of the bottom of pots and pans should be 6 ½" to 7" and with a maximum cooking capacity of 1 ½ quarts.
3. Do not use the pots and pan of smaller diameter than the hot plate.

START USING THE HOT PLATE

1. Turn the temperature control knob to your desired cooking setting.
2. Quick Temperature guide:
 - Warm:** keeping food warm
 - Low:** Slow cooking, stewing, sauce thickening
 - Medium:** Shallow frying of meat or pan-fried dishes, soup making
 - High:** To bring food to boil rapidly, steaming, stir frying
3. After the cooking is finished, turn temperature control knob to OFF position.
4. Be cautious that the hot plate cooking surface will remain HOT for a while even after you turn it OFF. Always wait for the hot plate to cool completely before cleaning or storage.

CAUTIONS

1. Do not touch the surface of hot plate when in operation as they are HOT.
2. Do not immerse the hot plate in any liquid.
3. Do not allow the power cord to come in contact with any hot surfaces of the hot plate.
4. Do not leave the hot plates ON without attended.

(CAUTIONS CONTINUED)

5. Avoid dripping soup or any greasy liquid on the surface of hot plate while cooking.
6. Do not use the pots and pans that are of smaller diameter than the hot plate.

ADDITIONAL SAFETY CAUTIONS

1. Never use the pots and pans with uneven bottom to cook on the hot plate.
2. The hot plate is designed only for heating and cooking food, and must only be used with cooking pots and pans placed on it.
3. The hot plate must be turned OFF and disconnect from power when not in use.
4. The pots and pans to be used on hot plate should not project beyond the hot plate or intrude into the area of close proximity of the controls.

HOW TO CLEAN

1. Turn the hot plate OFF and then unplug.
2. Wait for the hot plate to cool completely before any cleaning.
3. Clean the enamel body of hot plate with a damp cloth by using non-abrasive household detergent. Wipe it clean thoroughly.
4. Clean the cooking plate surface with household cleaning powder and wipe clean with a damp cloth. Let it dry before using.
5. The commercial cleaners made specially for hot plates are recommended to use for preserving the original finish of the hot plate.

RECIPES

HONEY MUSTARD CHICKEN SANDWICH

Makes 2 sandwiches

- 1/4 cup honey mustard dressing
- 1 tsp black pepper
- 2 tbsp of olive oil
- 2 boneless, skinless chicken breasts (about 4 oz. Each)
- 2 lettuce leaves
- 2 tomato slices
- 4 sweet pickle slices
- 4 whole wheat buns
- 2 slices Swiss cheese

Pat chicken breasts dry with paper towel. Marinate Chicken with honey mustard and black pepper, add salt to taste. Place chicken in a bowl and refrigerate for 30 minutes.

Heat a 6" skillet at medium setting. Add 1 ½ tablespoon of olive oil. Pan fry chicken breast for about 6 to 8 minutes each side. Turn the temperature down to low setting and cook until chicken is done. Combine lettuce, tomato, pickles, cheese and add chicken breasts to make 2 sandwiches.

LEMON FISH FILLET

Makes 2 servings

- 1 lb. Fish fillet; skinless
- ½ tsp salt
- ½ tsp Saki
- 1 egg; beaten
- 1 cup dried bread crumbs
- ½ cup of flour
- Lemon Sauce:
 - 1/3 lemon juice
 - 1 cup water
 - 1/3 cup cornstarch
 - 1 tsp sugar
 - 1 tsp soy sauce
 - 1 tsp crushed red pepper
 - 1 tsp finely chopped fresh ginger

Marinate fish with salt and wine. Heat a skillet with 1 cup of vegetable oil at high setting.

Coat fish with flour, dip into beaten egg and then press on bread crumbs. Pan fry in skillet until the fillet is evenly golden brown, for about 3 minutes at each side. Combine lemon sauce ingredients in a small sauce pan to a boil and cook at medium heat for 2 minutes. Pour sauce over fish fillet and serve hot.

SPAGHETTI WITH GARLIC AND OLIVE OIL

- ½ lb. Dried Spaghetti
- 6 cloves, peeled fresh garlic
- ¼ cup olive oil
- ½ tbsp of melted margarine
- ½ cup chopped Italian sausages
- ¼ cup shredded cheese
- ½ tsp black pepper and salt to taste

Cook pasta in a 8" pot at medium setting. Drain cooked pasta. Heat olive oil and margarine in a fry pan. Add garlic, sausage and cook for about 3 minutes. Add pasta in fry pan. Stir to mix pasta with garlic and sausages. Cook at medium setting for about 6 to 8 minutes. Add salt and black peeper to taste. Serve hot with toasted garlic bread.

BEEF MEDLEY MEAL

- ½ lb. Beef fillet, 1" cubed
- ½ beef broth
- 2 tsp butter
- 1 tsp ketchup
- 1½ cup of mixed vegetables; chopped into 1" cubes
- 1 tbsp finely chopped garlic
- ½ tsp onion salt
- 5 oz. of cooked egg noodles or rice

Heat butter in a skillet at medium setting. Cook beef fillet cubes until golden brown on all sides, about 8 minutes. Remove beef to a medium plate. Mix wine, beef broth, ketchup in a small bowl, pour mixture in skillet and cook for 5 minutes.

Add mixed vegetables and chopped fresh garlic. Add garlic salt to taste and cook for about 6 minutes. Add beef cubes and stir into vegetables. Add flour or cornstarch solution to thicken the sauce if desired. Cooked for about 4 minutes. Serve hot with cooked egg noodles or rice.

LIMITED WARRANTY

Aroma Housewares Company warrants this product free from defects in material and workmanship for one year from provable date of purchase. Within this warranty period, Aroma Housewares Company will repair or replace, at its option, defective parts at no charge, provided the product is returned, freight prepaid with proof of purchase and U.S.. \$6.00 for shipping and handling charges to Aroma Housewares Company. Please call the toll free number below for return authorization number. Allow 2-4 weeks for return shipping.

This warranty does not cover improper installation, misuse, abuse or neglect on part of the owner. Warranty is also invalid in any case that the product is taken apart or serviced by an unauthorized service station.

This warranty gives you specific legal rights and they may vary from state to state.

AROMA HOUSEWARES COMPANY
6469 Flanders Drive
San Diego, California 92121
1-800-276-6286
M-F, 8:30 AM - 5:00 PM, Pacific Time
Website: www.aromaco.com