

AROMA®



instruction manual

ASP-610

Hot Pot
(shabu-shabu)

Questions or concerns about your Aroma product?

www.AromaCo.com/Support

1-800-276-6286

DISCOVER
more of our
products!



Multicookers/
Rice Cookers



Pot-style
Rice Cookers



Water Kettles



Indoor Grills



Woks

AROMA®

To Enhance and Enrich Lives.

Here at Aroma we strive to make a difference—to design and distribute products that enhance and enrich people's lives.

Aroma offers an array of exceptional products to make cooking simple and satisfying. Discover other countertop appliances and cookware from our current product lineup to complement your kitchen.

Stay connected for more recipe ideas and monthly giveaways!



www.AromaTestKitchen.com



[/AromaHousewares](https://www.instagram.com/AromaHousewares)



IMPORTANT SAFEGUARDS

Basic safety precautions should always be followed when using electrical appliances, including the following:

1. **Important: Read all instructions carefully before first use.**
2. Do not touch hot metal surface. Use handles or knobs.
3. To protect against electrical shock, do not immerse the appliance, cord or plug in water or other liquid. See instructions for cleaning.
4. Close supervision is necessary when any appliance is used by or near children. This appliance is not intended to be used by children.
5. Unplug from outlet when not in use and before cleaning. Allow to cool before putting on or taking off parts, and before cleaning the appliance.
6. Do not operate any appliance with a damaged cord or plug or after the appliance malfunctions or has been damaged in any manner. Contact Aroma Customer Service for examination, repair or adjustment.
7. The use of accessory attachments not recommended by Aroma Housewares, may result in fire, electrical shock or injury.
8. Do not use outdoors.
9. Do not let the cord touch hot surfaces or hang over the edge of a counter or table.
10. Do not place on or near a hot gas or electric burner or in a heated oven.
11. Extreme caution must be used when using or moving an appliance containing hot liquids.
12. Do not use the appliance for anything other than its intended use.
13. Do not clean with metal scouring pads. Pieces may break off the pad and touch electrical parts, creating a risk of electric shock.
14. Be sure to use on a dry, level and heat-resistant surface.
15. This appliance should be operated on a separate electrical circuit from other operating appliances. If the electrical circuit is overloaded with other appliances, this appliance may not operate properly.
16. This appliance is not intended for deep frying food.
17. To disconnect, turn any control to OFF, then remove the plug from the wall outlet. Always attach plug to appliance first, then plug into the wall outlet.

SAVE THESE INSTRUCTIONS



IMPORTANT SAFEGUARDS (CONT.)

Parts Identification

Short Cord Instructions

1. A short power-supply cord is provided to reduce the risks resulting from becoming entangled in or tripping over a longer cord.
2. Longer extension cords are available and may be used if care is exercised in their use.
3. If a longer extension cord is used:
 - a.) The marked electrical rating of the extension cord should be at least as great as the electrical rating of the appliance.
 - b.) The longer cord should be arranged so that it will not drape over the countertop or tabletop where it can be pulled by children or tripped over unintentionally.
 - c.) If the appliance is of the grounded type, the extension cord should be a grounding 3-wire cord.

DO NOT DRAPE CORD!

KEEP AWAY FROM CHILDREN!

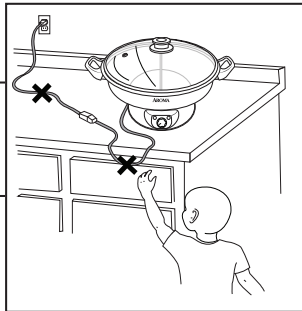

Grounding Instructions

This appliance must be grounded while in use to protect the operator from electrical shock. The appliance is equipped with a 3-conductor cord and a 3-prong grounding-type plug to fit the proper grounding-type receptacle.

The appliance has a plug that looks like Figure A. An adapter, Figure B, should be used for connecting Figure A plugs to two-prong receptacles. The grounding tab, which extends from the adapter, must be connected to a permanent ground such as a properly grounded outlet box as shown in Figure C using a metal screw.

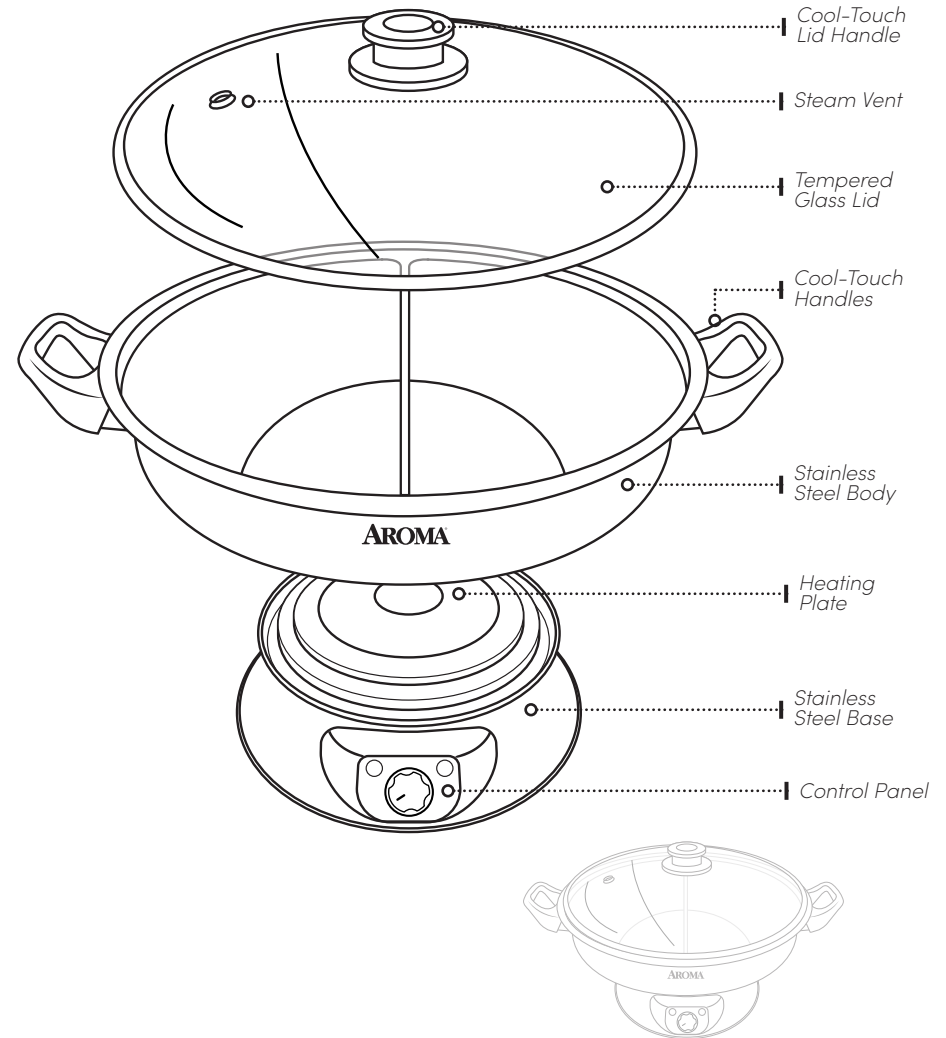
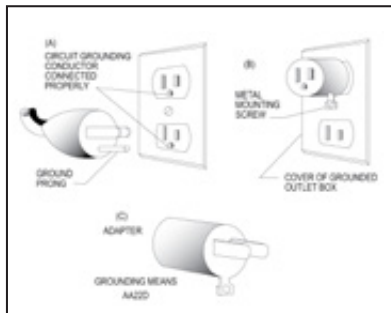

THIS APPLIANCE IS FOR HOUSEHOLD USE ONLY.

Controls/Functions

Temperature Dial

Manually set to desired temperature. (150°F-450°F)

BEFORE FIRST USE

1. Read all instructions and important safeguards.
2. Remove all packaging materials and check that all items have been received in good condition.
3. Tear up all plastic bags and dispose of them properly as they can pose a suffocation or choking risk to children.
4. Wash stainless steel body and glass lid in warm, soapy water. Rinse and dry thoroughly. Wipe the surface of the stainless steel base and heating plate with a damp cloth. Do not immerse the base of the Hot Pot in water or other liquids.
.....

TO ASSEMBLE

1. Locate the lid handle. The screw needed to assemble the handle to the lid has been screwed into the lid handle.
2. Using a Phillips screwdriver, unscrew the screw from the handle.
3. Place the handle on top of the lid, so that it lines up with the hole in the lid correctly.
4. Place the screw beneath the lid so that it fits correctly through the hole in the lid and into the handle.
5. Using a Phillips screwdriver, tighten the screw until the handle is securely attached to the lid.

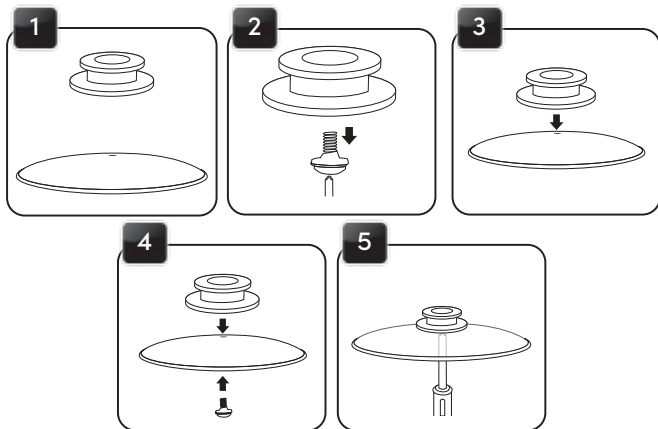

Note:

- Do not use abrasive cleaners or scouring pads.
- Do not immerse the stainless steel base, cord or plug in water at any time.
- Any other servicing should be performed by Aroma® Housewares.

TO COOK

1. Before each use, check for debris on the surface of the heating plate and remove if there is any present.
2. Pour desired broth into the body of the Hot Pot.
3. Place the body on the heating base and ensure it's properly in place by turning until both surfaces meet snugly.
4. Plug the power cord into a 120V AC wall outlet. The **POWER** indicator light will illuminate.
5. Adjust the temperature control dial to the desired temperature. The **HEAT** indicator light will illuminate, indicating that the cooking process has begun.
.....

TO CLEAN

1. Wash the stainless steel body and tempered glass lid in warm, soapy water. Rinse and dry thoroughly.
2. Do not immerse the base, cord or plug in water or any other liquid.
3. Wipe the surface of the base with a damp cloth.
4. Dry all parts thoroughly. Reassemble for next use.
.....



Caution:

The Hot Pot's stainless steel body will get hot; use caution when handling.

Note:

- Temperature settings on the adjustable dial range from **Low**, **Medium**, to **High** Heat.
- The stainless steel body and lid are dishwasher safe.

Helpful Hints:

For a quick and simple meal, simply pour your favorite packaged soup broth into your Hot Pot and bring to a boil by turning the dial to **High**. Serve with your choice of hot pot ingredients such as meat, vegetables, tofu or seafood. To prepare your own Hot Pot broth, see "Recipes" on pages **8-9**.

RECIPES

Chicken Tomato Soup Base

2	onions, diced
2	celery stalks, minced
6	tomatoes, peeled and diced
16 cups	chicken stock
6 tsp	olive oil
2 tbsp	ketchup
2 tsp	salt
4 tsp	sugar
2 tbsp	cooking wine

Add oil to a large saucepan and apply medium heat. Once heated, add in diced onions and sauté until soft and transparent. Mix in diced tomatoes, tomato juice and ketchup and simmer until the consistency of the base thickens. Once thickened, stir in minced celery, chicken stock, salt and sugar. Transfer the prepared broth to your Hot Pot and bring to a boil by turning the dial to **High** heat. Serve and enjoy with other hot pot ingredients such as meat, vegetables, tofu or seafood.

SERVES 4-6.

.....

Milk Broth Base

8 cups	milk
1	onion, diced
7 cups	chicken stock
3 tbsp	butter
2 tsp	salt
2 tsp	sugar

Add butter to a large saucepan and apply medium heat. Once the butter is melted, add in diced onions and sauté until transparent and soft. Pour in chicken stock, milk, salt and sugar and heat thoroughly. Transfer the prepared broth to your Hot Pot and bring to a boil by turning the dial to **High** heat. Serve and enjoy with other hot pot ingredients such as meat, vegetables, tofu or seafood.

SERVES 4-6.

.....

RECIPES

Curry Soup Base

13 cups	vegetable stock
3 tbsp	sugar
3 tbsp	oil
15	cloves garlic, minced
1 inch	ginger, cut into thick slices
3 cup	coconut milk
6 tbsp	Thai red curry paste, to taste

Add oil to a large frying pan, and apply medium heat. Once heated, add in garlic and ginger and sauté until fragrant. Stir in the vegetable stock and coconut milk and heat thoroughly. Whisk in the Thai red curry paste until the paste is dissolved then cover and let simmer for 5 minutes. Remove the large ginger slices from the broth. Transfer the prepared broth to your Hot Pot and bring to a boil by turning the dial to **High** heat. Serve and enjoy with other hot pot ingredients such as meat, vegetables, tofu or seafood.

SERVES 4-6.

.....

Sauerkraut Soup Base

6 cups	sauerkraut
2	green onions, chopped
9	cloves garlic, minced
1 inch	ginger root, sliced
400g	pork belly, thinly sliced
12 cups	chicken broth
3 tbsp	oil
2 tbsp	salt
2 tbsp	sugar
3 tbsp	cooking wine
3 tbsp	pepper powder

Add oil to a large saucepan and apply medium heat. Once heated, add in garlic and ginger and sauté until fragrant. Add in the thinly sliced pork belly and stir-fry for 5 minutes or until the pork belly has browned. Once browned, add in sauerkraut and sauté for another 6 minutes. Pour in chicken broth, salt, sugar and cooking wine and heat thoroughly. Transfer the prepared broth to your Hot Pot and bring to a boil by turning the dial to **High** heat. Serve and enjoy with other hot pot ingredients such as meat, vegetables, tofu or seafood.

SERVES 4-6.

.....

For additional recipes, visit us at

www.AromaCo.com or at www.AromaTestKitchen.com

For additional recipes, visit us at

www.AromaCo.com or at www.AromaTestKitchen.com



To Enhance and Enrich Lives.



www.AromaCo.com